



# MORSE DI PRECISIONE TOOL MAKER VISE SINERGYA



**Emmepi Utensileria s.r.l.**  
SEDE LEGALE  
+39 0445 576210  
Via Lago di Albano, 5 - 36015 Schio (VI)



**Cuma**  
DIVISIONE PRODUZIONE  
+39 049 870 0810  
Viale della Regione Veneto, 22, 35127 Padova (PD)

[utensileria.it](http://utensileria.it)  
[ordini@utensileria.it](mailto:ordini@utensileria.it)

# Tool Maker Vise

Grinding & EDM Accessories

SINERGYA

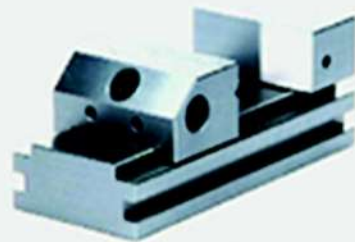
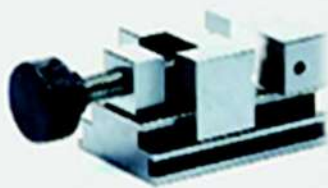

Stainless Steel Precision Vises

TMV/05-2026



**B01~10**

**Tool Maker Vise (Stainless)**



52700 B01



52715 B01



52720 B01



52725 B01



52730 B02



52735 B02



52740 B02



52745 B02



52750 B03



52755 B03



52760 B03



52765 B03



52770 B04



52775 B04



52780 B04



52790 B04



52800 B05



52820-60/70 B07



52820-90 B07



52830 B09



52840 B10



52850 B10

**B11~16**

**Tool Maker Vise**



52860 B11



52870 B11



52880 B12



52890 B12



52900 B13



52910 B13



52920 B14



52930 B14



52940 B15



52950 B15



52960 B16



52970 B16



**B17~26****Wire EDM Clamp (Stainless)****53000 B17****53005 B17****53010 B17****53015 B18****53020 B18****53025 B18****53030 B19****53035 B19****53040 B20****53045 B20****53050 B21****53055 B21****53060 B22****53065 B22****53068 B23****53070 B24****53100 B25****53105 B25****53110 B25****53112 B26****53115 B26****53120 B26****B27~36****Wire EDM Clamp (Stainless)****53125 B27****53130 B27****53135 B28****53140 B28****53145 B29****53148 B30****53150 B31****53155 B31****53160 B31****53165 B32****53168 B33****53170 B33****53175 B34****53180 B35****53185 B36**

B43~47

EDM Fixture Clamp (Stainless)



53300 B43



53310 B43



53320 B43



53330 B44



53340 B44



53342 B45



53346 B45



53350 B46



53360 B46



53370 B46



53380 B46



53390 B47



53400 B47

C07~08

Block / Sine



54080 C07



54090 C07



54100 C08

D01~05

Measuring Fixture / Pin & Block Gauges



55000 D01



55004 D01



55006 D02



55008 D02



55010 D03



55015 D03



55020 D03



55030 D04



55040 D04



55050 D04



55060 D05

D38~38

Tool Pre-setter / Fixture for CMM



55610-01 D38



55610-02 D38



G102~104

## Milling Vise



65006 G102



65008-01 G102



65008-02 G102



65010-80 G103



65010-100 G103



65010-125 G104



65010-300 G104

G155~16

## Milling Clamp Fixture



65700 G155



65710 G155



65720 G156



65730 G156



65740 G156



65750 G157



65760 G157



65770 G157



65780 G158



65790 G158



65800 G158



65830 G160

H01~06

## Scroll Chuck for Lathe



66800 H01

H07~12

## Steel Body Scroll Chuck for Lathe



66915 H12



# Stainless Tool Maker Vice

Material : SUS440      Parallelism: within 0.003mm/100mm  
 Hardness: HRC48°~55°      Squareness: within 0.003mm/100mm

Unit:mm

## 52700 VJ10

▶ A delicate vise and suitable for clamping precision workpiece

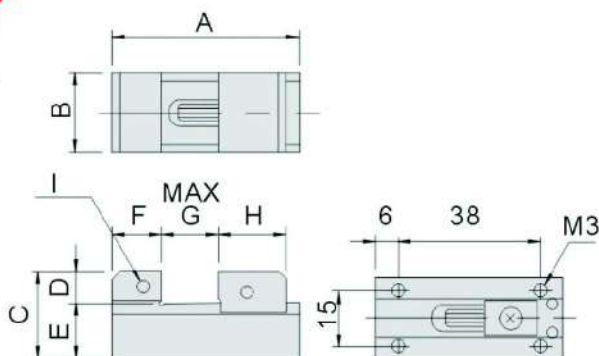

Spec	Model	VJ10
A		50
B		21
C		23.5
D		8.5
E		15
F		13
G		15
H		18
I		M3
N.W.		0.15kg

## 52715 VLW10

▶ Two way clamping and suitable for applying in EDM machine

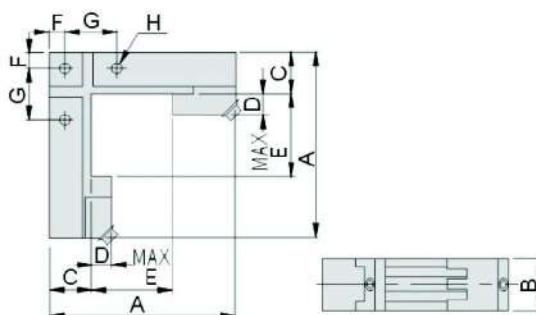

Spec	Model	VLW10
A		90
B		25
C		20
D		10
E		40
F		7.5
G		25
H		M5
N.W.		0.5kg

## 52720 VL10

▶ Compact version precision vise, suitable for small precision workpiece, apply by wrench.  
 ▶ VL10-2 has step groove on jaws.



52720-01 VL10-1  
 52720-02 VL10-2

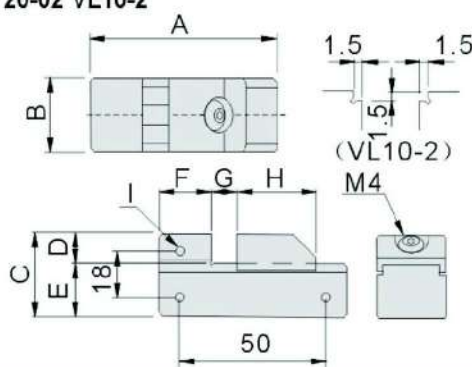

Spec	Model	VL10-1	VL10-2
A		65	65
B		25	25
C		32	32
D		12	12
E		20	20
F		20	20
G		20	20
H		25	25
I		M4	M4
N.W.		0.25kg	0.25kg

## 52725 VL20/30

▶ Suitable for high precision processing grinding / milling / EDM... apply by wrench to lock tight.



52725-20 VL20  
 52725-30 VL30

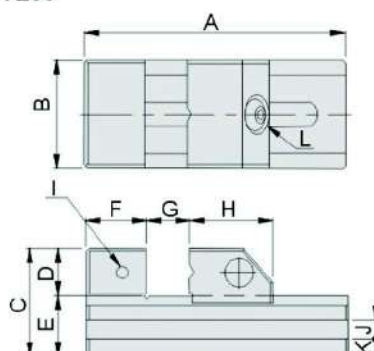

Spec	Model	VL20	VL30
A		140	180
B		50	72
C		53	62
D		25	30
E		28	32
F		25	35
G		0~75	0~100
H		40	45
I		M6	M6
J(WXD)		6x5	8x7
K		8.5	9
N.W.		1.5kg	3.0kg

Material :SUS440 Parallelism:within 0.003mm/100mm  
 Hardness:HRC48°~55° Squareness:within 0.003mm/100mm

Unit:mm

## 52770 VE30/50

52770-30 VE30  
52770-50 VE50

- 45° angle design for the jaw, suitable for precision and small workpiece which needs to form 45° angle.
- Standard equipment for adjusting work height position.

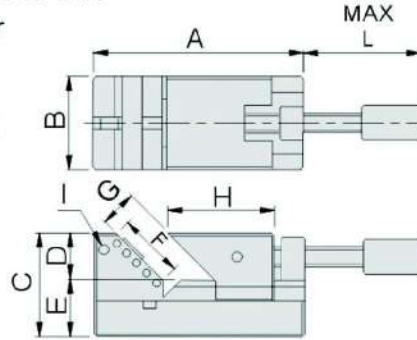

Spec	Model	VE30	VE50
A		62	90
B		30	50
C		37	44
D		15	20
E		22	24
F		21	33.9
G		0~11	26
H		37.5	45.4
I		M4	M4
L		33.5	65
N.W.		0.5kg	0.7kg

## 52775 VR40

- This vise has compact structure vise with special design to prevent any floating of workpiece when clamped.

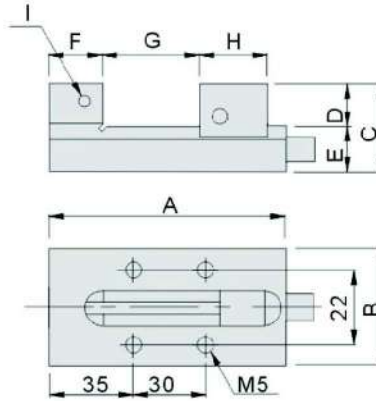

Spec	Model	VR40
A		100
B		40
C		40
D		15
E		25
F		25
G		0~40
H		25
I		M4
N.W.		1.0kg

## 52780 VK35

- This vise is adopting new structure and easier operation with higher accuracy and stability.

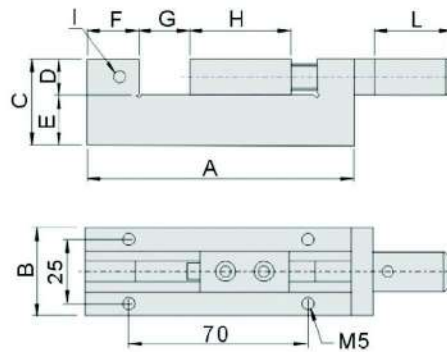
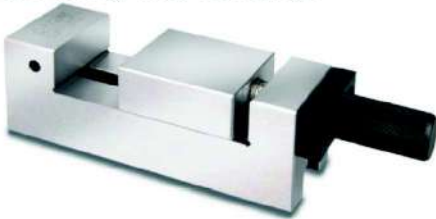

Spec	Model	VK35
A		105
B		35
C		35
D		15
E		20
F		20
G		0~30
H		40
I		M4
L		30
N.W.		1.1kg

## 52790 VSP50

- Precision sine vise, suitable for precision and small workpiece as well as EDM work.

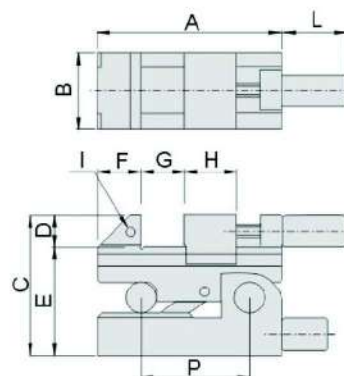

Spec	Model	VSP50
A		85
B		35
C		65
D		15
E		50
F		20
G		0~30
H		24
I		M4
L		37
P		50
N.W.		1.0kg

TOOL MAKER VISE

# Tool Maker Vise

## 52800 VV Super Precision Tool Maker Vise

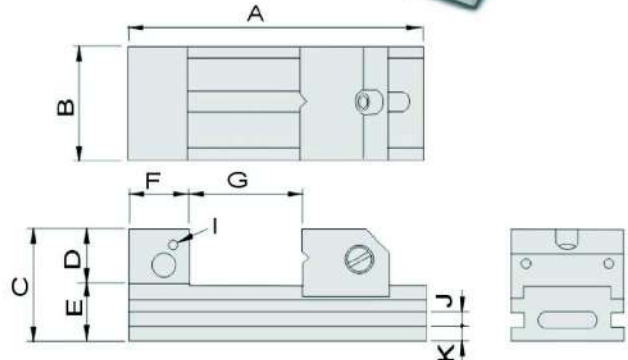

### Features :

- ▲ VV Tool Maker Vise is made of high quality alloy tool steel (SKS3)
- ▲ Special design to prevent distortion during clamping ensuring the accuracy for work processing on workpieces.
- ▲ With quick adjust spring function, clamping jaw can move and position easily.
- ▲ Material:SKS3
- ▲ Hardness:HRC58°~60°
- ▲ Sub-zero treatment:-185°C
- ▲ Parallelism:within 0.003mm/100mm
- ▲ Squareness:within 0.004mm/100mm

Unit:mm

Order No.	Model	A	B	C	D	E	F	G	I	J	K	N.W.
52800-20	VV20	150	48	53	25	28	25	0-70	M5	6	8.5	1.7kg
52800-30	VV30	190	73	70	35	35	38	0-100	M6	8	9.5	4.5kg
52800-40	VV40	230	98	80	40	40	46	0-125	M6	10	10	8.4kg
52800-50	VV50	300	125	98	48	50	60	0-160	M8	12	13	17.4kg
52800-60	VV60	350	150	100	50	50	60	0-210	M8	12	13	22.7kg

### Super Precision Tool Maker Vise

■ New improved VV Tool Maker Vise before clamping operation.

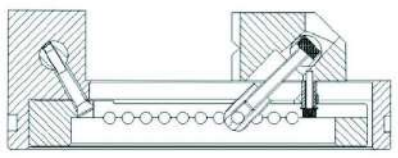

■ Improved VV Tool Maker Vise, inner block face force when clamping and no twist or distortion is existing and achieve higher accuracy and stability.

### Principle of anti-distortion

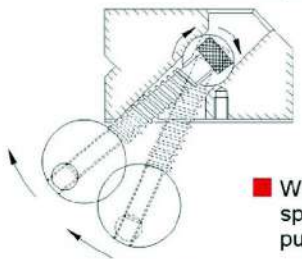
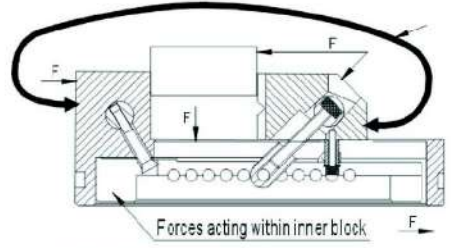

Upward spring

■ When the fixed pin face the pressure from the spring, it generates upward twisting torque and push the screw match with the inner block.

### General Tool Maker Vise

■ V series Tool Maker Vise before clamping operation

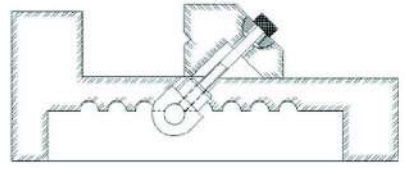

■ Conventional vise has distortion or twist when clamping workpiece and thus lead to poor accuracy.

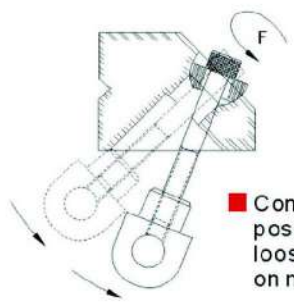
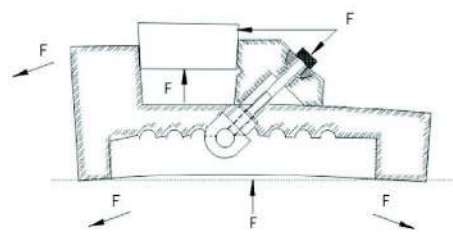

■ Conventional vise needs to position the fix pin when you loose the screw, it all depends on manual work.

TOOL MAKER VISE

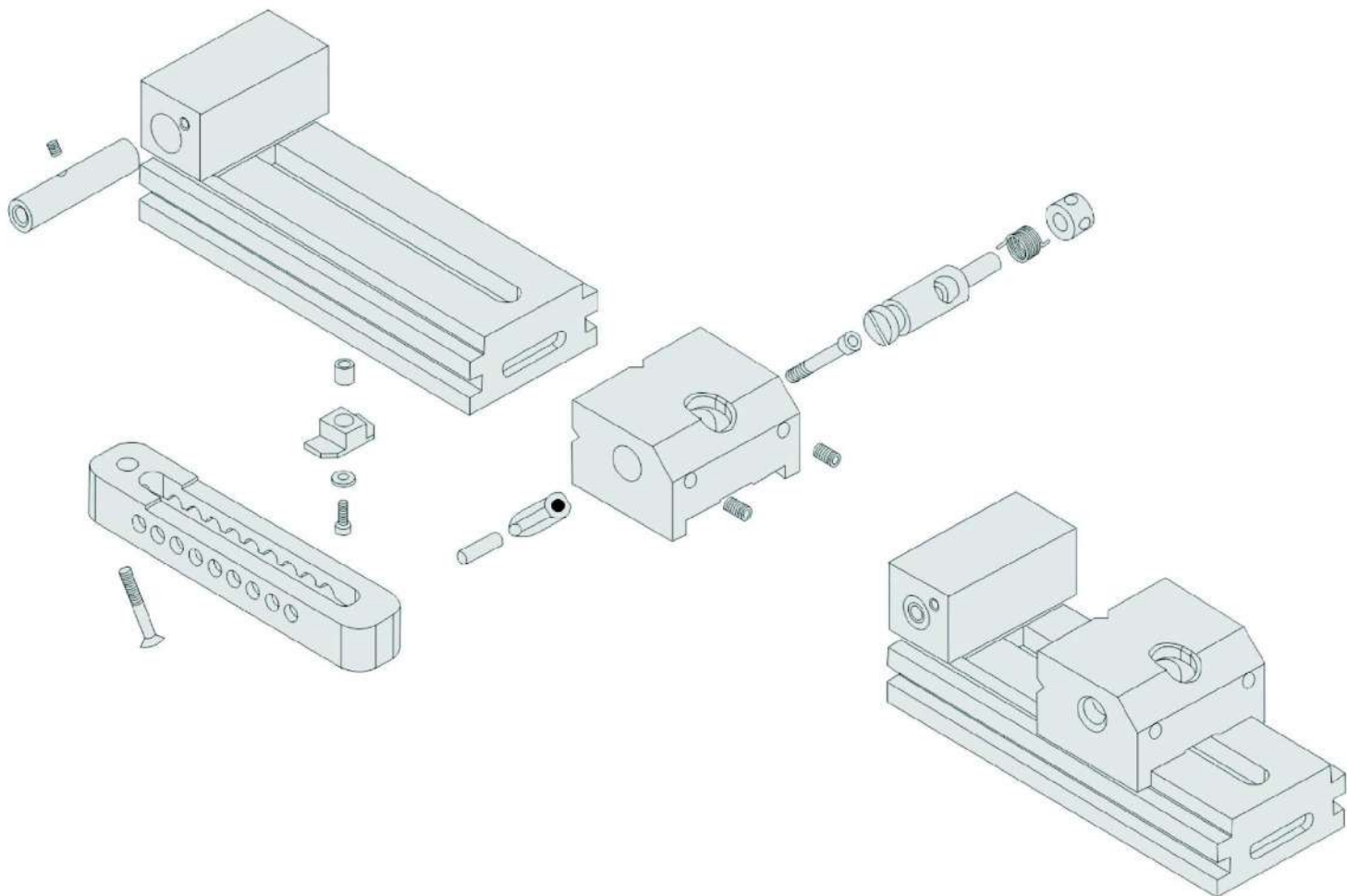
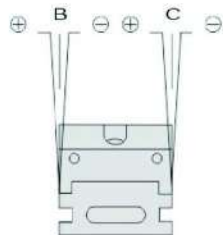
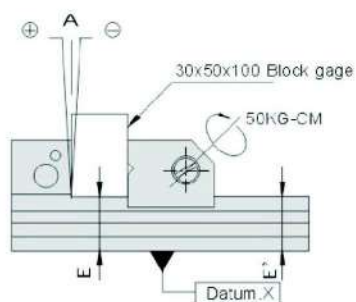
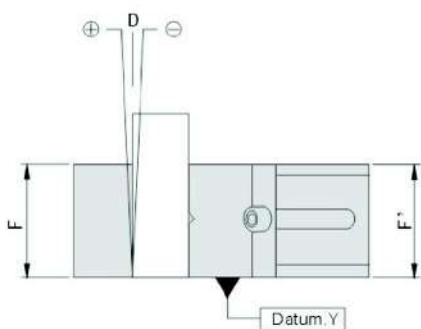
**52800****VV****Super Precision Tool Maker Vise****TOOL MAKER VISE**Unit:  $\mu\text{m}$ 

Position	Inspection description	Tolerance
<b>A</b>	Perpendicularity to Datum X	$\pm 4$
<b>B</b>	Perpendicularity to Datum X	$\pm 4$
<b>C</b>	Perpendicularity to Datum X	$\pm 4$
<b>D</b>	Perpendicularity to Datum Y	$\pm 4$
<b>E</b>	Perpendicularity to Datum X	$\pm 3$
<b>F</b>	Perpendicularity to Datum Y	$\pm 3$

# Tool Maker Vise

**52820** HU Tool Maker Vise

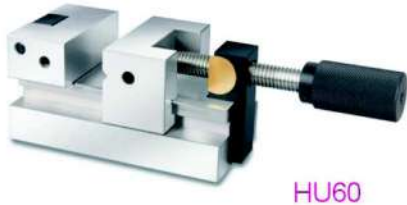

HU60



HU70



HU90

## Features :

- ▶ Made of high quality alloy tool steel (SKS3) and tempering & sub-zero treatment.
- ▶ Anti-distortion design with screw rod function to lock, suitable for applying on precision processing work.

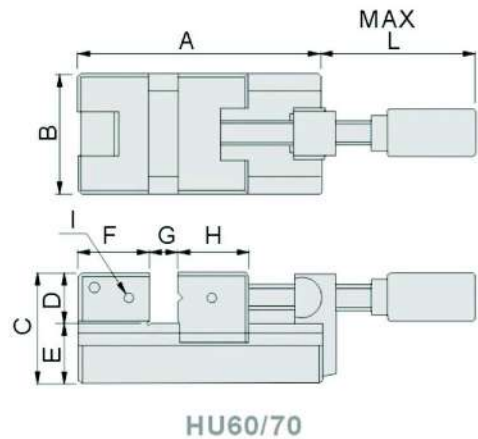

HU60/70

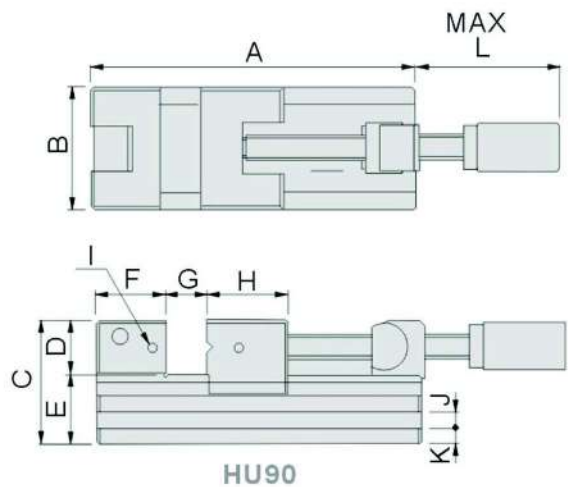

HU90

Material	SKS
Hardness	HRC56 <sup>o</sup> ~60 <sup>o</sup>
Parallelism	within 0.003mm/100mm
Squareness	within 0.005mm/100mm

Order No.	Model	A	B	C	D	E	F	G	H	I	L	N.W.
52820-60	HU60	122	60	60	25	35	35	0~47	40	M6	105	2.5kg
52820-70	HU70	172	70	70	30	40	40	0~80	45	M6	149.5	4.7kg

Unit:mm

Order No.	Model	A	B	C	D	E	F	G	H	I	J(WxD)	K	L	N.W.
52820-90	HU90	237	90	90	40	50	50	0~125	50	M6	10x7	10	201	10.3kg

Unit:mm

# Anti-distortion

HU60/HU70/HU90 are all adopting inbuilt Anti-distortion

Comparison



HU60



HU70



HU90

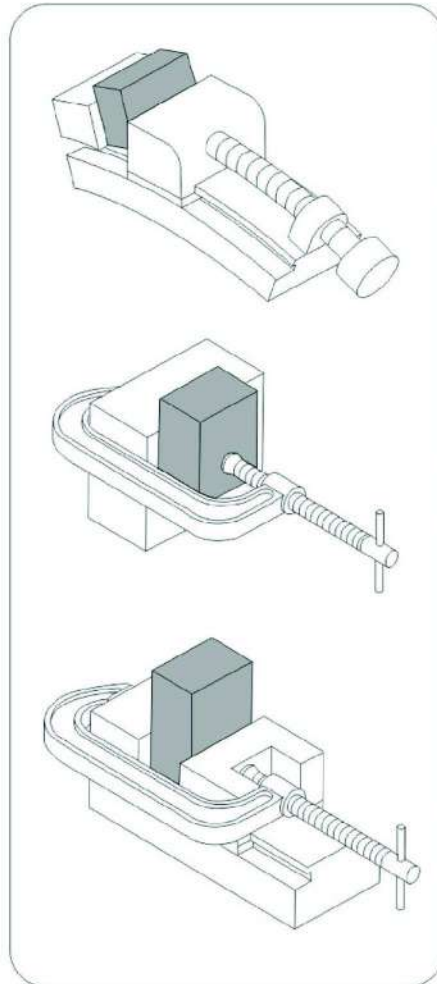

General Tool Maker Vise will distort from clamping stress and thus impede the precision processing.

Applying fixture block is essential for high precision processing, however, it is not cost effective.

Applying fixture block and the vise it achieve cost effective and high precision processing.

Making inbuilt fixture into vise and it help the precision processing due to the distortion stress will react on fixture. Thus no distortion influent the parallelism and perpendicularity.

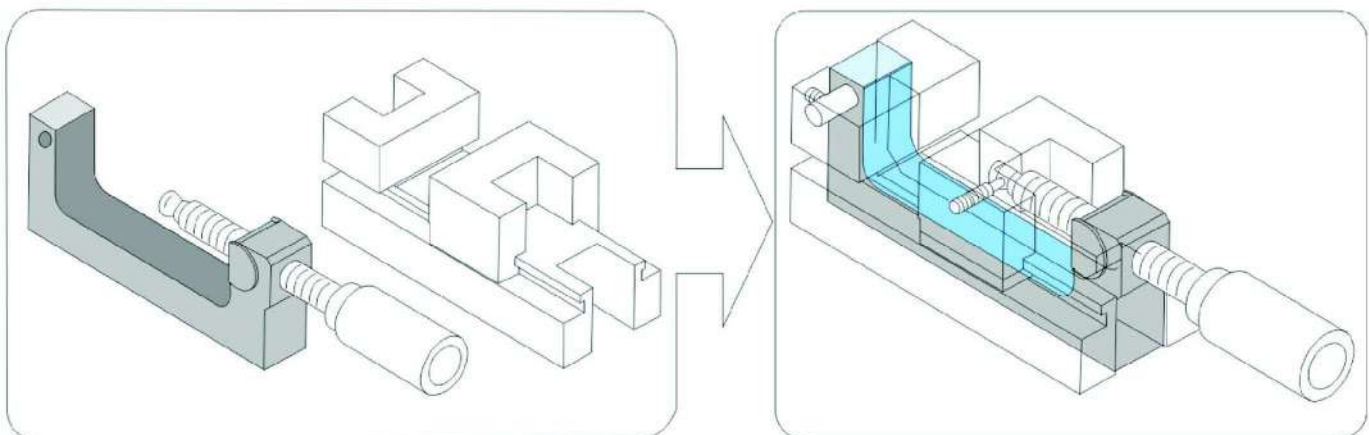

TOOL MAKER VISE

# Tool Maker Vise

**52830**

SV

Super Precision Tool Maker Vise

SV34



SV70

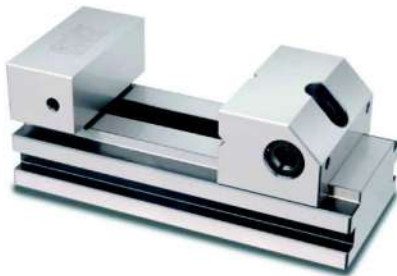

SV90



## Features :

- ▲ Made of high quality alloy tool steel (SKS3) with Sub-zero treatment.
- ▲ The best type of Tool Maker Vise both in structure and accuracy.
- ▲ Due its high precision and stability, it is well-known in Japan and Europe and sold to worldwide range.
- ▲ Single side oblique angle design can automatically mend the distortion from the body.
- ▲ Material:SKS
- ▲ Hardness:HRC58°~60°
- ▲ Sub-zero treatment:-185°C
- ▲ Parallelism:within 0.003mm/100mm
- ▲ Squareness:within 0.004mm/100mm

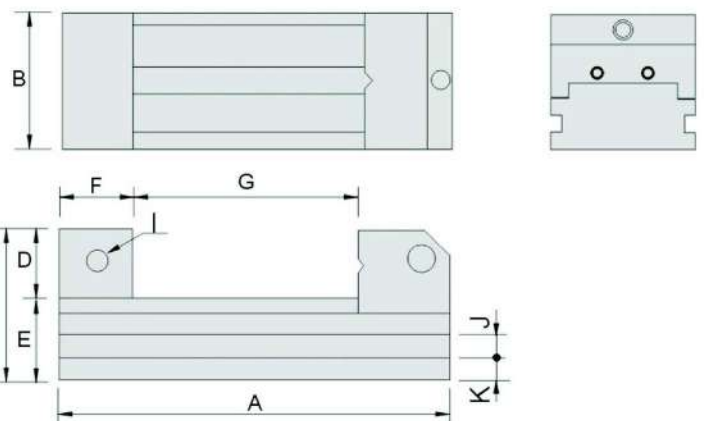

Unit:mm

Order No.	Model	A	B	C	D	E	F	G	I	J	K	N.W.
52830-34	SV34	75	34	35	15	20	20	0-25	M4	-	-	0.5kg
52830-45	SV45	110	45	45	20	25	25	0-50	M5	6	8	1.0kg
52830-70	SV70	160	70	62	30	32	33	0-80	M6	8	9	3.0kg
52830-90	SV90	210	90	80	40	40	40	0-115	M6	10	12	6.7kg
52830-120	SV120	286	120	90	40	50	60	0-150	M6	12	14	14.9kg

**52840****A****Super Precision Tool Maker Vise**

A20

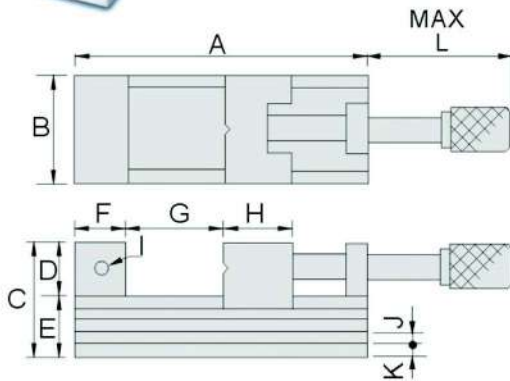
**Features :**

- ▶ A type Super Precision Tool Maker Vise has complete specifications with handle screw bar design. Hex wrench can be applied for lock tighter.
- ▶ Precision screw bar and screw nut, ensure the lasting durability, every part is precision ground square and parallel.
- ▶ Single side oblique angle design can automatically mend the distortion from the body.
- ▶ Material:SK2
- ▶ Hardness:HRC56°~58°
- ▶ Parallelism:within 0.003mm/100mm
- ▶ Squareness:within 0.004mm/100mm

Unit:mm

Order No.	Model	A	B	C	D	E	F	G	H	I	J	K	L	N.W.
52840-20	A20	140	48	55	25	30	25	0-75	40	M6	-	-	117	2.3kg
52840-25	A25	160	63	69	30	39	30	0-85	45	M6	8	9	129	3.8kg
52840-30	A30	180	73	78	35	43	35	0-95	50	M6	8	10	132	6.0kg
52840-40	A40	230	98	92	45	47	45	0-120	50	M8	10	11	172	11.3kg

TOOL MAKER VISE

**52850****AS****Super Precision Tool Maker Vise**

AS60



AS70

**Features :**

- ▶ AS type Super Precision Tool Maker Vise has complete specifications with handle screw bar design. Made of high quality alloy tool steel (SKS3) with Sub-zero treatment.
- ▶ The best type of Tool Maker Vise both in structure and accuracy and every part is precision ground square and parallel.
- ▶ Single side oblique angle design can automatically mend the distortion from the body.

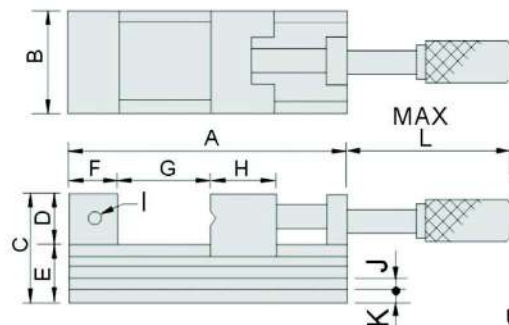

Unit:mm

- Material:SKS
- Hardness:HRC58°~60°
- Sub-zero treatment:-185°C
- Parallelism:within 0.002mm/100mm
- Squareness:within 0.003mm/100mm

Order No.	Model	A	B	C	D	E	F	G	H	I	J	K	L	N.W.
52850-60	AS60	92	60	50	25	25	25	0-32	30	M5	6	4.5	60	1.6kg
52850-70	AS70	165	70	62	30	32	33	0-80	45	M6	7	8	140	4.0kg
52850-90	AS90	212	90	80	40	40	40	0-120	50	M6	9	9	192	8.4kg



# Tool Maker Vice

## 52860 V100 Precision Sine Vice



### Features :

- ▶ Made of high quality alloy tool steel (SKS3) with Sub-zero treatment.
- ▶ Suitably using in grinding, cutting, drilling, marking and measuring.
- ▶ New structure design make easier operation with higher accuracy and stability.

- ▶ Material:SKS
- ▶ Hardness:HRC58°~60°
- ▶ Sub-zero treatment:-185°C
- ▶ Parallelism:within 0.003mm/100mm
- ▶ Squareness:within 0.005mm/100mm
- ▶ Angle tolerance within 15 Sec..

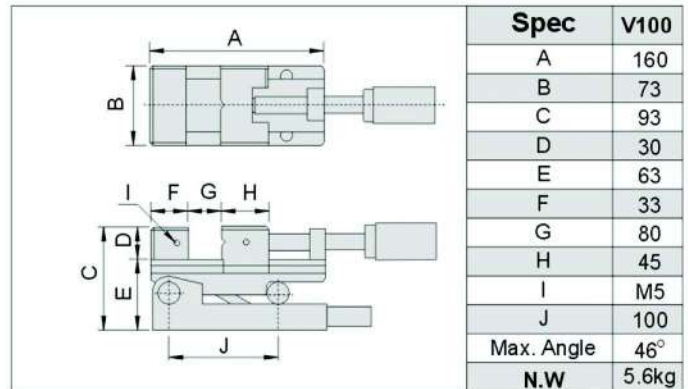

TOOL MAKER VISE

## 52870 VC100 Precision Sine Vice

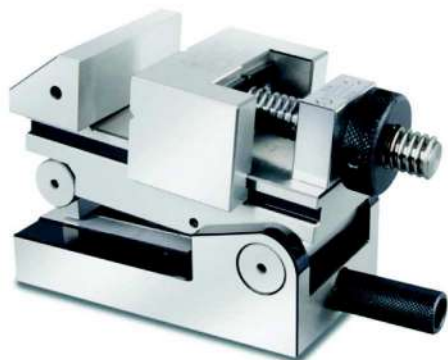

### Features :

- ▶ Made of high quality alloy tool steel (SKS3) with Sub-zero treatment.
- ▶ Suitably using in grinding, cutting, drilling, marking and measuring.
- ▶ New structure design make easier operation with higher accuracy and stability.

- ▶ Material:SKS
- ▶ Hardness:HRC58°~60°
- ▶ Sub-zero treatment:-185°C
- ▶ Parallelism:within 0.003mm/100mm
- ▶ Squareness:within 0.005mm/100mm
- ▶ Angle tolerance within 15 Sec..

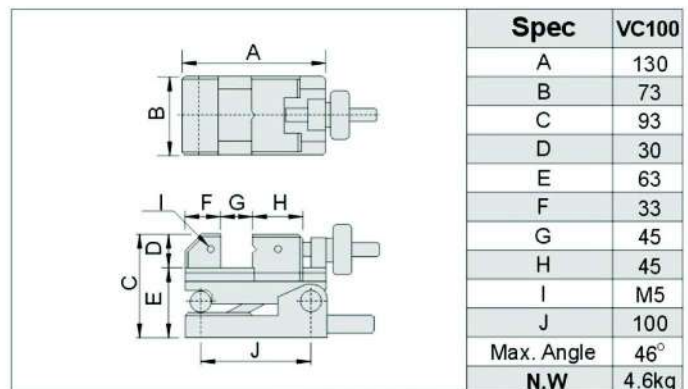

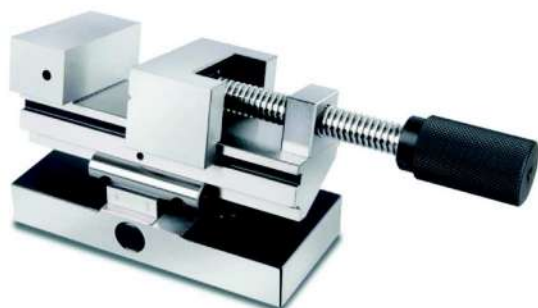
**52880****L50****Precision Sine Vise**

- ▶ Material:SKS
- ▶ Hardness:HRC58°~60°
- ▶ Sub-zero treatment:-185°C
- ▶ Parallelism:within 0.003mm/100mm
- ▶ Squareness:within 0.005mm/100mm
- ▶ Angle tolerance within 15 Sec..

**Features :**

- ▶ Made of high quality alloy tool steel (SKS3) with Sub-zero treatment.
- ▶ Suitably using in grinding, cutting, drilling, marking and measuring.
- ▶ New structure design make easier operation with higher accuracy and stability.
- ▶ The quotient is equal to the sine of the resulting angle, which can be found in a trigonometric table or by using a scientific calculator.

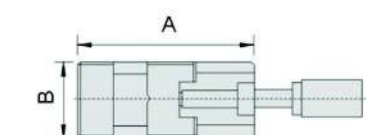
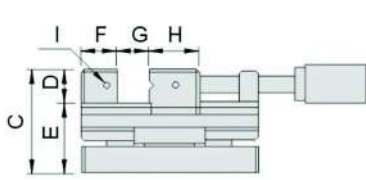
		Spec	L50
		A	160
		B	73
		C	93
		D	30
		E	63
		F	33
		G	80
		H	45
		I	M5
		Max. Angle	46°
		N.W	5.8kg

**TOOL MAKER VISE****52890****CSV100****Precision Compound Sine Vise**

- ▶ Material:SKS
- ▶ Hardness:HRC58°~60°
- ▶ Sub-zero treatment:-185°C
- ▶ Parallelism:within 0.003mm/100mm
- ▶ Squareness:within 0.005mm/100mm
- ▶ Angle tolerance within 15 Sec..

**Features :**

- ▶ Made of high quality alloy tool steel (SKS3) with Sub-zero treatment.
- ▶ Suitably using in grinding, cutting, drilling, marking and measuring.
- ▶ New structure design make easier operation with higher accuracy and stability.
- ▶ The quotient is equal to the sine of the resulting angle, which can be found in a trigonometric table or by using a scientific calculator.

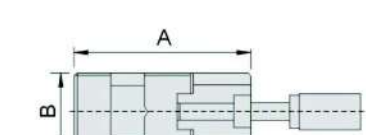
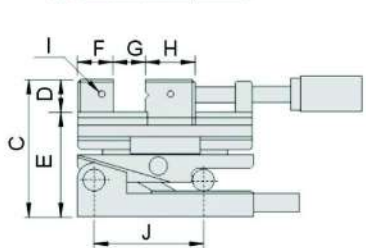
		Spec	CSV100
		A	160
		B	73
		C	124
		D	30
		E	94
		F	33
		G	80
		H	45
		I	M5
		J	100
		Max. Angle	46°
		N.W	7.5kg

# Tool Maker Vise

## 52900 VSB Tool Maker Vise



### Features :

- ▶ New structure design make easier operation with higher accuracy and stability.
- ▶ Made of SK2 to ensure hardness and accuracy.

Material	SK2
Hardness	HRC55°~60°
Parallelism	within 0.003mm/100mm
Squareness	within 0.005mm/100mm

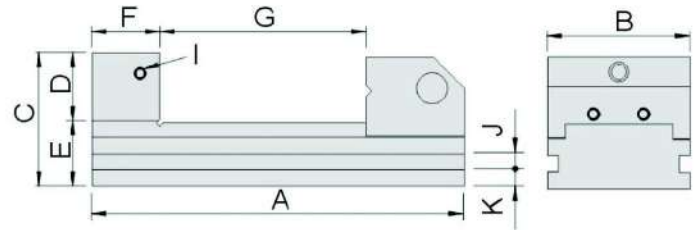

Unit:mm

Order No.	Model	A	B	C	D	E	F	G	I	J	K	N.W.
52900-15	VSB15	105	36	48	20	28	25	0-40	M6	7	9	0.8kg
52900-20	VSB20	150	48	53	25	28	25	0-75	M6	6	8.5	1.5kg
52900-25	VSB25	176	63	59	30	29	30	0-95	M6	8	7.5	2.6kg
52900-30	VSB30	190	73	68	35	33	35	0-105	M6	8	9	4.0kg
52900-40	VSB40	245	98	90	45	45	45	0-135	M6	10	14	9.5kg

## 52910 VS Tool Maker Vise



### Features :

- ▶ Precision Tool Maker Vises are suitable for all machining operations.

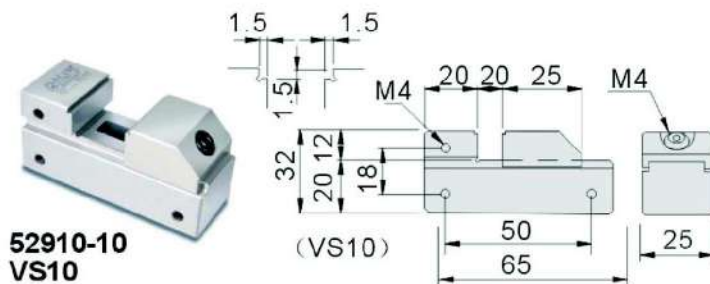
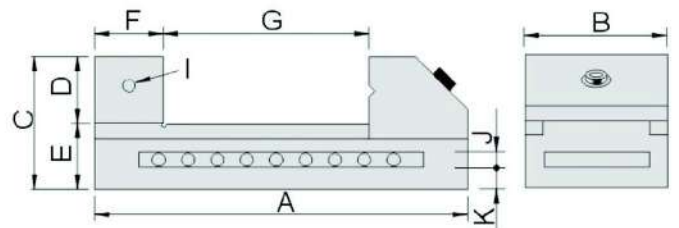

52910-10 VS10

Material	SK2
Hardness	HRC55°~60°
Parallelism	within 0.003mm/100mm
Squareness	within 0.005mm/100mm

Unit:mm

Order No.	Model	A	B	C	D	E	F	G	I	J	K	N.W.
52910-15	VS15	105	36	48	20	28	25	0-40	M6	7	9	0.9kg
52910-20	VS20	150	50	53	25	28	30	0-80	M6	8	8	1.6kg
52910-25	VS25	175	63	63	32	31	35	0-90	M6	10	11	2.9kg
52910-30	VS30	190	73	70	35	35	35	0-100	M6	10	12	4.3kg
52910-35	VS35	235	88	80	40	40	40	0-130	M8	12	14	6.8kg
52910-40	VS40	245	100	90	45	45	45	0-130	M8	12	16	10kg
52910-50	VS50	285	125	100	50	50	45	0-160	M8	14	18	15kg

**52920**

vs

**Tool Maker Vise(Big)****Features :**

- ▶ One piece body construction.
- ▶ Holes and locking set screw provide adjustable positions.

Material	SK2
Hardness	HRC55°~60°
Parallelism	within 0.003mm/100mm
Squareness	within 0.005mm/100mm

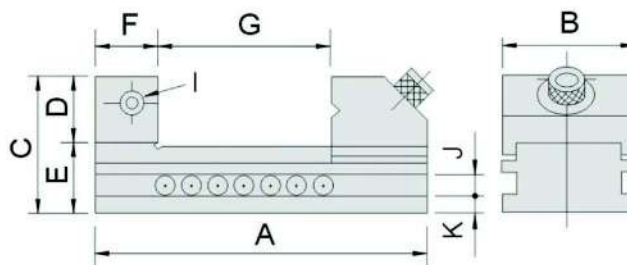

Unit:mm

Order No.	Model	A	B	C	D	E	F	G	I	J	K	N.W.
52920-60	VS60	330	150	100	50	50	50	0-180	M8	14	18	20kg

TOOL MAKER VISE

**52930**

VB

**Tool Maker Vise****Features :**

- ▶ One piece body construction.
- ▶ Holes and locking set screw provide adjustable positions.

Material	tool steel
Hardness	HRC52°~58°
Parallelism	within 0.005mm/100mm
Squareness	within 0.008mm/100mm

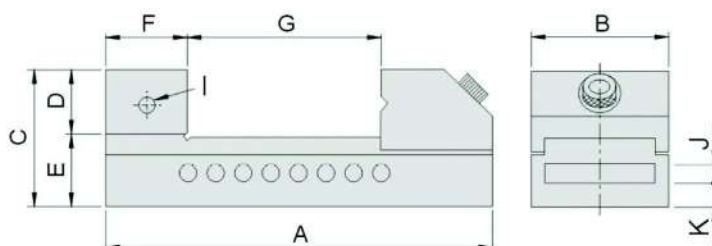

Unit:mm

Order No.	Model	A	B	C	D	E	F	G	I	J	K	N.W.
52930-15	VB15	100	36	48	20	28	25	0-40	M5	8	8	1.0kg
52930-20	VB20	150	50	53	25	28	30	0-80	M6	8	8	1.7kg
52930-25	VB25	175	63	63	32	31	35	0-90	M6	10	11	3.0kg
52930-30	VB30	190	73	70	35	35	35	0-100	M6	10	12	4.2kg
52930-35	VB35	235	88	80	40	40	40	0-130	M8	12	14	7.0kg
52930-40	VB40	245	100	90	45	45	45	0-130	M8	12	16	9.0kg
52930-50	VB50	285	125	100	50	50	45	0-160	M8	14	18	15.0kg



# Tool Maker Vice

**52940**

SVA

Tool Maker Vice

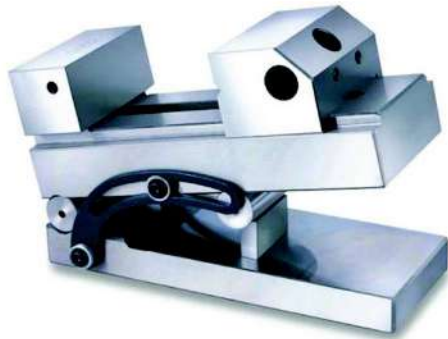

Material	SK2
Hardness	HRC52°~58°
Parallelism	within 0.005mm/100mm
Squareness	within 0.005mm/100mm

## Features :

- ▲ Angles are figured by the following formula: The buildup under and roll is divided by the distance between the rolls. The quotient is equal to the sine of the resulting angle, which can be found in a trigonometric table or by using a scientific calculator.
- ▲ Maximum angle of 46°.

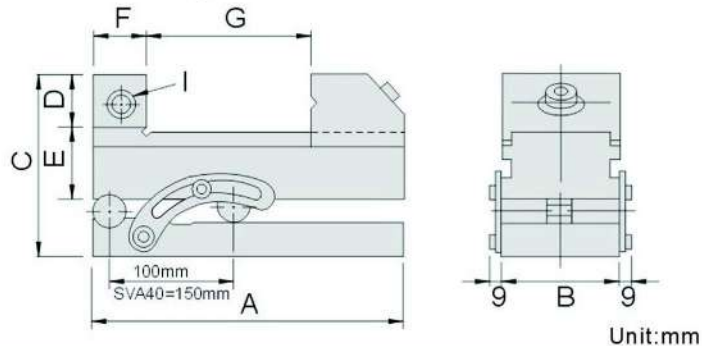

Order No.	Model	A	B	C	D	E	F	G	I	N.W.
52940-20	SVA20	150	48	88.5	25	28	25	0-75	M6	2.9kg
52940-25	SVA25	176	63	94.5	30	29	30	0-85	M6	4.6kg
52940-30	SVA30	190	73	103.5	35	33	35	0-95	M6	6.4kg
52940-40	SVA40	245	98	126.5	45	45	45	0-125	M6	14.1kg

**52950**

SV

Tool Maker Sine Vice



Material	SK2
Hardness	HRC52°~58°
Parallelism	within 0.005mm/100mm
Squareness	within 0.005mm/100mm

## Features :

- ▲ Angles are figured by the following formula: The buildup under and roll is divided by the distance between the rolls. The quotient is equal to the sine of the resulting angle, which can be found in a trigonometric table or by using a scientific calculator.
- ▲ Maximum angle of 46°.

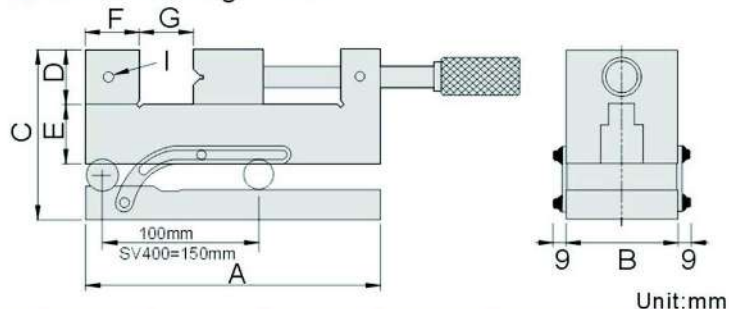

Order No.	Model	A	B	C	D	E	F	G	I	N.W.
52950-200	SV200	156	48	87.5	25	27	25	0-63	M6	3.7kg
52950-250	SV250	176	63	98.5	30	33	30	0-73	M6	6.0kg
52950-300	SV300	190	73	103.5	35	33	35	0-76	M6	8.0kg
52950-400	SV400	255	98	120.5	40	42	40	0-120	M8	16.0kg

**52960**

VSD

Tool Maker Vice



Material	SK2
Hardness	HRC52°~58°
Parallelism	within 0.004mm/100mm
Squareness	within 0.006mm/100mm

**Features :**

- ▶ New structure design for minimum clearance occurred when lock tight also handle with hex hole can apply hex wrench to lock tighter. Simple dismantle the screw bar when worn.

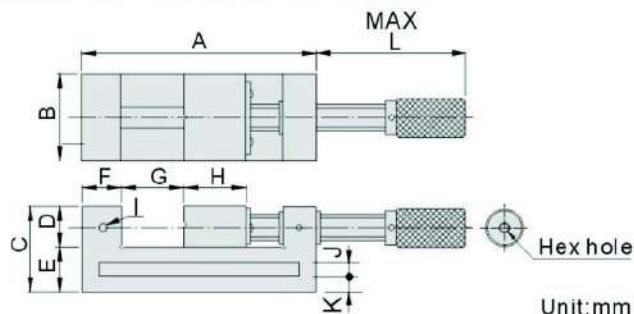

Unit:mm

Order No.	Model	A	B	C	D	E	F	G	H	I	J	K	L	N.W.
52960-20	VSD20	156	48	52	25	27	25	0-63	34	M6	8	9.5	125	2.3kg
52960-25	VSD25	176	63	63	30	33	30	0-73	40	M6	10	11.5	147	4.0kg
52960-30	VSD30	190	73	73	35	38	35	0-76	45	M6	10	14	151	5.5kg
52960-40	VSD40	255	98	82	40	42	40	0-120	50	M8	12	15	196	11.0kg
52960-50	VSD50	310	125	100	50	50	50	0-152	57	M8	14	18	231	18.3kg
52960-60	VSD60	325	150	100	50	50	50	0-165	60	M8	14	18	245	20.0kg

**52970**

PGV

Precision Hydraulic Vice

**Features :**

- ▶ Adopting hydraulic structure with stronger clamping force.
- ▶ High precision and quality, popular in worldwide.

Material	SNCM21
Hardness	HRC56°~60°
Max clamping force	1500kgf
Parallelism	within 0.005mm/100mm
Squareness	within 0.005mm/100mm

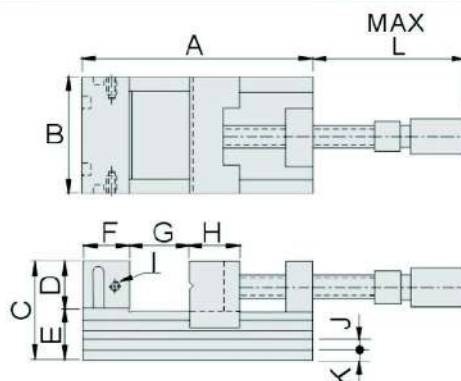
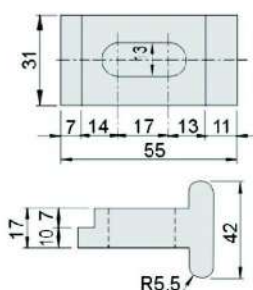
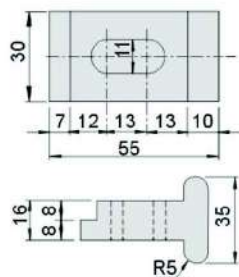

Unit:mm

Order No.	Model	A	B	C	D	E	F	G	H	I	J (WXD)	K	L	N.W.
52970-100	PGV100	220	100	80	40	40	40	110	50	M10	9x7	9.5	235	11.1kg
52970-125	PGV125	300	125	90	40	50	60	165	70	M10	11x7	12.5	290	20.6kg
52970-150	PGV150	340	150	95	45	50	60	210	70	M10	12x11	14	340	23.5kg



# Wire EDM Extensions Clamp

**53000**

EW10

Wire EDM Clamp

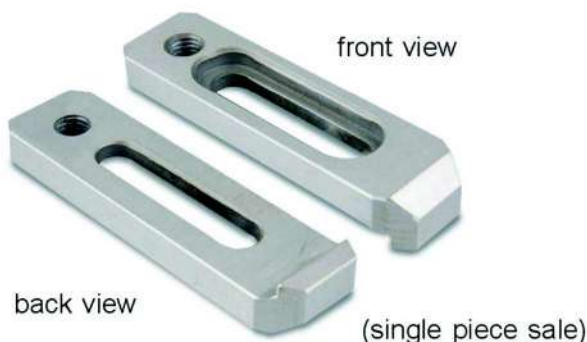

Spec.: L80 x W22 x T8(M8)

## Features :

- ▶ Suitable for using in WEDM machines.
- ▶ Adopting stainless steel with heat treatment, stable and distortion free.
- ▶ Based on the type of WEDM machines and workpiece applied, it can make various combinations.
- ▶ Material: SUS420
- ▶ Hardness: HRC35°~ 40°

**53005**

EW20

Wire EDM Clamp



## Features :

- ▶ Suitable for using in WEDM machines.
- ▶ Adopting stainless steel with heat treatment, stable and distortion free.
- ▶ Based on the type of WEDM machines and workpiece applied, it can make various combinations.
- ▶ Material: SUS420
- ▶ Hardness: HRC35°~ 40°

Unit:mm

Order No.	Model	Spec.	Mark
53005-01	EW20-01	70x22x8(M8)	Ultra-thin
53005-02	EW20-02	70x22x12(M8)	Standard

**53010**

EW30

Wire EDM Clamp

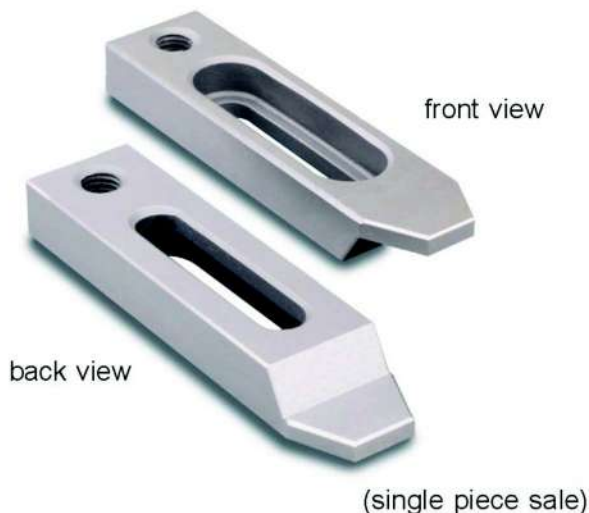

## Features :

- ▶ Suitable for using in WEDM machines.
- ▶ Adopting stainless steel with heat treatment, stable and distortion free.
- ▶ Based on the type of WEDM machines and workpiece applied, it can make various combinations.
- ▶ Material: SUS420
- ▶ Hardness: HRC35°~ 40°

Unit:mm

Order No.	Model	Spec.	Mark
53010-01	EW30-01	90x22x8(M8)	Ultra-thin
53010-02	EW30-02	90x22x12(M8)	Standard

**53015****EW40****Wire EDM Extensions Fixed Block**

Spec.: L50 x W20 x T5 M6 x 3

**Features :**

- ▶ Suitable for using in WEDM machines.
- ▶ Adopting stainless steel with heat treatment, stable and distortion free.
- ▶ Based on the type of WEDM machines and workpiece applied, it can make various combinations.
- ▶ Material: SUS440
- ▶ Hardness: HRC50°~ 55°

**53020****EW50****Wire EDM Extensions Fixed Block**

Spec.: L65 x W20 x T5 M5 x 4

**Features :**

- ▶ Suitable for using in WEDM machines.
- ▶ Adopting stainless steel with heat treatment, stable and distortion free.
- ▶ Based on the type of WEDM machines and workpiece applied, it can make various combinations.
- ▶ Material: SUS440
- ▶ Hardness: HRC50°~ 55°

**53025****EW60****Wire EDM Extensions Clamp**

Spec.: L120 x W50 x T15 + H5

**Features :**

- ▶ Suitable for using in WEDM machines.
- ▶ Adopting stainless steel with Sub-zero Treatment after Vacuum Heat Treatment, stable and distortion free.
- ▶ Based on the type of WEDM machines and workpiece applied, it can make various combinations.
- ▶ Material: SUS440
- ▶ Hardness: HRC50°~ 55°
- ▶ Parallelism: within 0.003/100mm
- ▶ Squareness: within 0.005/100mm

# Wire EDM Extensions Clamp

**53030**

EW70

Wire EDM Extensions Clamp



Spec.: L120 x W100 x T15 + H5

## Features :

- ▶ Suitable for using in WEDM machines.
- ▶ Adopting stainless steel with Sub-zero Treatment after Vacuum Heat Treatment, stable and distortion free.
- ▶ Based on the type of WEDM machines and workpiece applied, it can make various combinations.
- ▶ Material: SUS440
- ▶ Hardness: HRC50<sup>o</sup>~ 55<sup>o</sup>
- ▶ Parallelism: within 0.003/100mm
- ▶ Squareness: within 0.005/100mm

**53035**

EW80

Wire EDM Extensions Clamp

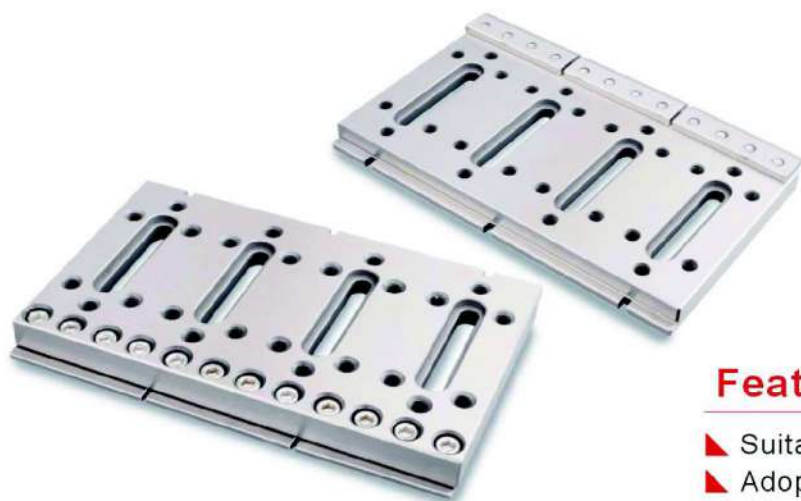

Spec.: L120 x W200 x T15 + H5

## Features :

- ▶ Suitable for using in WEDM machines.
- ▶ Adopting stainless steel with Sub-zero Treatment after Vacuum Heat Treatment, stable and distortion free.
- ▶ Based on the type of WEDM machines and workpiece applied, it can make various combinations.
- ▶ Material: SUS440
- ▶ Hardness: HRC50<sup>o</sup>~ 55<sup>o</sup>
- ▶ Parallelism: within 0.003/100mm
- ▶ Squareness: within 0.005/100mm

**53040**

EW90

**Wire EDM Extensions Clamp**

Spec.: L220 x W60 x T20 + H5

**Features :**

- ▶ Suitable for using in WEDM machines.
- ▶ Adopting stainless steel with Sub-zero Treatment after Vacuum Heat Treatment, stable and distortion free.
- ▶ Based on the type of WEDM machines and workpiece applied, it can make various combinations.
- ▶ Material: SUS440
- ▶ Hardness: HRC50<sup>o</sup>~55<sup>o</sup>
- ▶ Parallelism: within 0.003/100mm
- ▶ Squareness: within 0.005/100mm

**WIRE EDM  
EXTENSIONS CLAMP**
**53045**

EW100

**Wire EDM Extensions Clamp**

Spec.: L120 x W65 x T15 + H5

**Features :**

- ▶ Suitable for using in WEDM machines.
- ▶ Adopting stainless steel with Sub-zero Treatment after Vacuum Heat Treatment, stable and distortion free.
- ▶ Based on the type of WEDM machines and workpiece applied, it can make various combinations.
- ▶ Material: SUS440
- ▶ Hardness: HRC50<sup>o</sup>~55<sup>o</sup>
- ▶ Parallelism: within 0.003/100mm
- ▶ Squareness: within 0.005/100mm

# Wire EDM Extensions Clamp

**53050**

**EWA**

**Wire EDM Extensions Clamp Kit**



N.W. 6.6kg

## Features :

- ▲ Suitable for using in WEDM machines.
- ▲ Adopting stainless steel with Sub-zero Treatment after Vacuum Heat Treatment, stable and distortion free.
- ▲ Based on the type of WEDM machines and workpiece applied, it can make various combinations.
- ▲ Material: SUS440
- ▲ Hardness: HRC50<sup>o</sup>~ 55<sup>o</sup>
- ▲ Parallelism: within 0.003/100mm
- ▲ Squareness: within 0.005/100mm

## Kits including

No.	Kits Model	Q'ty	Page
<b>53035</b>	EW80	1PCS	Refer to P. B17~20
<b>53025</b>	EW60	3PCS	
<b>53000</b>	EW10	2PCS	
<b>53005-02</b>	EW20-2	2PCS	
<b>53010-02</b>	EW30-2	2PCS	

**53055**

**EWB**

**Wire EDM Extensions Clamp Kit**



N.W. 6.6kg

## Features :

- ▲ Suitable for using in WEDM machines.
- ▲ Adopting stainless steel with Sub-zero Treatment after Vacuum Heat Treatment, stable and distortion free.
- ▲ Based on the type of WEDM machines and workpiece applied, it can make various combinations.
- ▲ Material: SUS440
- ▲ Hardness: HRC50<sup>o</sup>~ 55<sup>o</sup>
- ▲ Parallelism: within 0.003/100mm
- ▲ Squareness: within 0.005/100mm

## Kits including

No.	Kits Model	Q'ty	Page
<b>53045</b>	EW100	6PCS	Refer to P. B17~20
<b>53000</b>	EW10	2PCS	
<b>53005-02</b>	EW20-2	2PCS	
<b>53010-02</b>	EW30-2	2PCS	

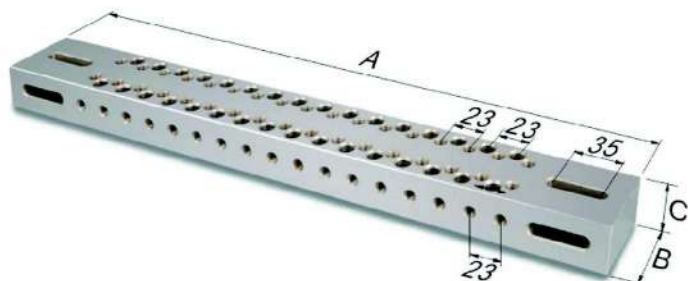
**53060****WPA****Ruler****Features :**

- ▶ Suitable for using in WEDM machines.
- ▶ Adopting stainless steel with Sub-zero Treatment after Vacuum Heat Treatment, stable and distortion free.
- ▶ Suitable for large and heavy workpieces' application.
- ▶ Material: SUS440
- ▶ Hardness: HRC50°~ 55°
- ▶ Parallelism: within 0.003/100mm
- ▶ Squareness: within 0.005/100mm

**Kits including**

Unit:mm

Order No.	Model	A	B	C	N.W.
<b>53060-01</b>	WPA-370	370	50	30	4.00kg
<b>53060-02</b>	WPA-450	450	50	30	5.00kg
<b>53060-03</b>	WPA-520	520	50	35	7.00kg
<b>53060-04</b>	WPA-550	550	60	35	9.00kg
<b>53060-05</b>	WPA-650	650	60	35	10.5kg

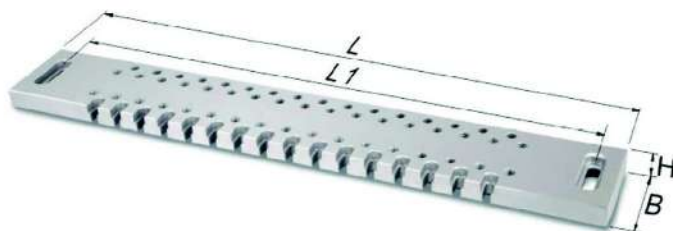
**53065****WPB****Ruler****Features :**

- ▶ Suitable for using in WEDM machines.
- ▶ Adopting stainless steel with Sub-zero Treatment after Vacuum Heat Treatment, stable and distortion free.
- ▶ Suitable for large and heavy workpieces' application.
- ▶ Material: SUS440
- ▶ Hardness: HRC50°~ 55°
- ▶ Parallelism: within 0.003/100mm
- ▶ Squareness: within 0.005/100mm

**Kits including**

Unit:mm

Order No.	Model	L	L1	B	H	N.W.
<b>53065-01</b>	WPB-370	370	320	75	20	4.00kg
<b>53065-02</b>	WPB-480	480	430	75	20	5.20kg
<b>53065-03</b>	WPB-520	520	480	75	20	6.00kg
<b>53065-04</b>	WPB-550	550	500	90	22	8.20kg
<b>53065-05</b>	WPB-600	600	550	90	22	9.00kg
<b>53065-06</b>	WPB-650	650	600	90	22	10.0kg
<b>53065-07</b>	WPB-750	750	700	90	22	11.3kg



# Wire EDM Extensions Clamp

**53068** WPT100 Adjustable Fixture For EDM



N.W. 6.8kg

X,Y,Z axis fine-tuning illustration

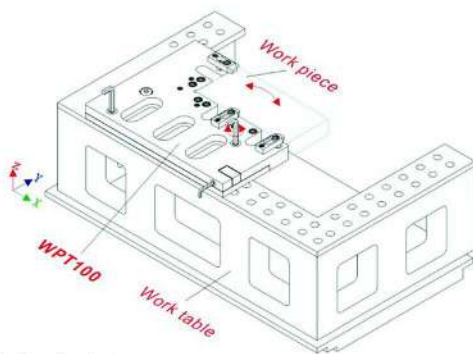

1. left & right

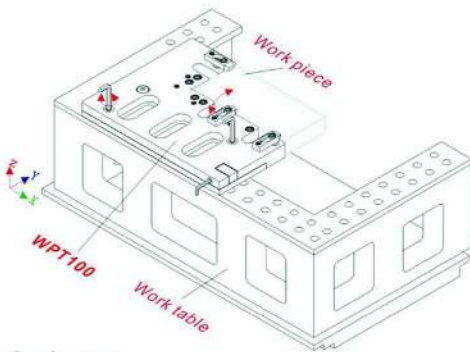

2. Up & down

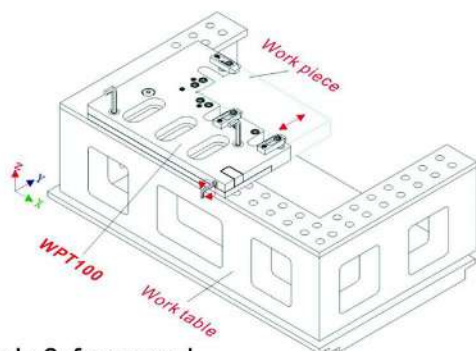

3. back & forward

## Features :

- ▶ Adopting stainless steel with Sub-zero Treatment after Vacuum Heat Treatment, stable and distortion free.
- ▶ With X,Y, and Z axis fine-tuning function.
- ▶ Material: SUS440
- ▶ Hardness: HRC45°~ 55°
- ▶ Parallelism: within 0.003/100mm
- ▶ Squareness: within 0.005/100mm

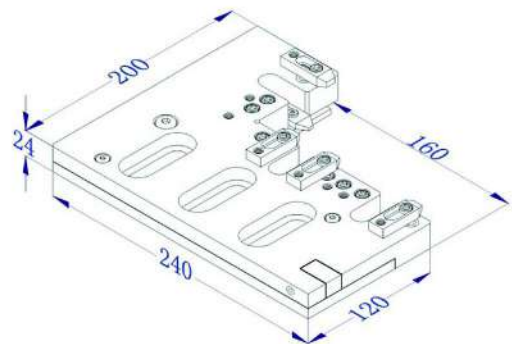

Installation illustration

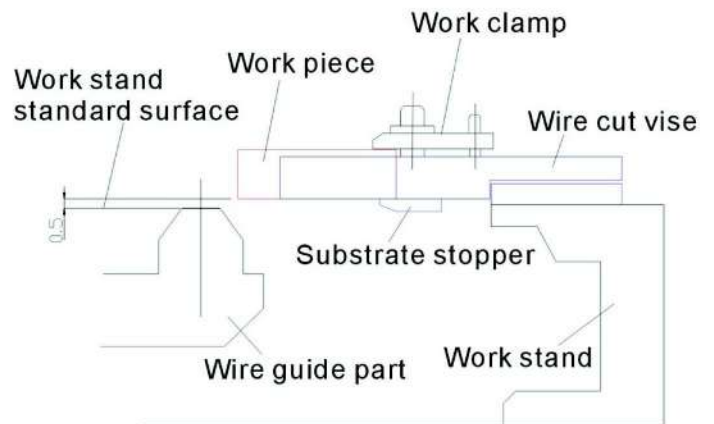

**53070****WPT200****Levelling Adjustable Universal Fixture**

### Features :

- ▶ Suitable for using in WEDM machines.
- ▶ Adopting stainless steel with Sub-zero Treatment after Vacuum Heat Treatment, stable and distortion free.
- ▶ Suitable for large and heavy workpieces' application.

### Application example:

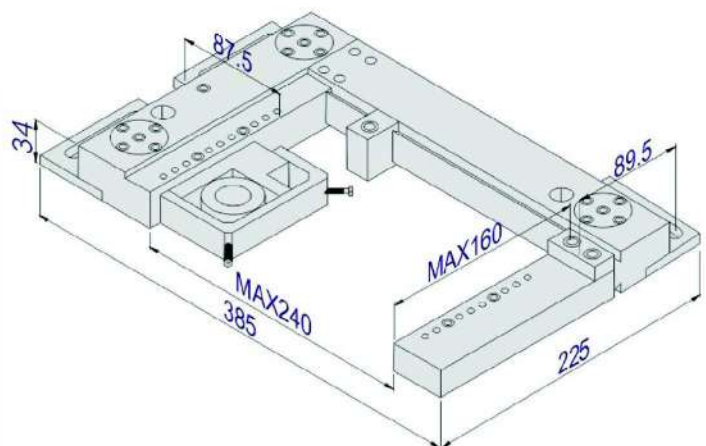
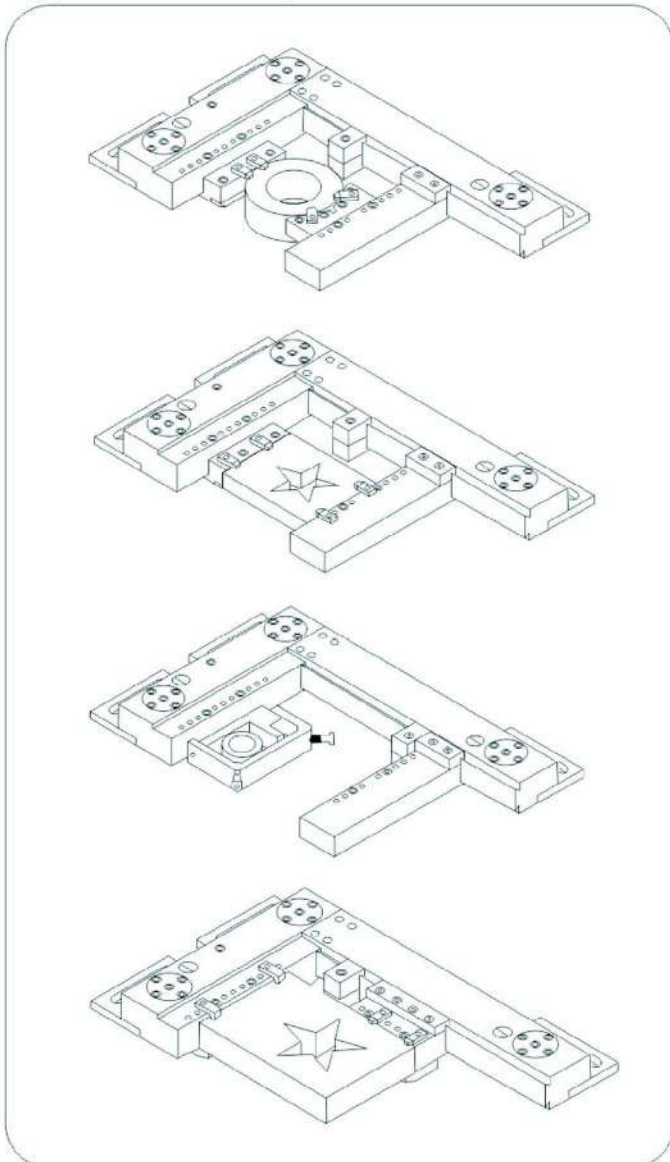

### Graphic of installation:

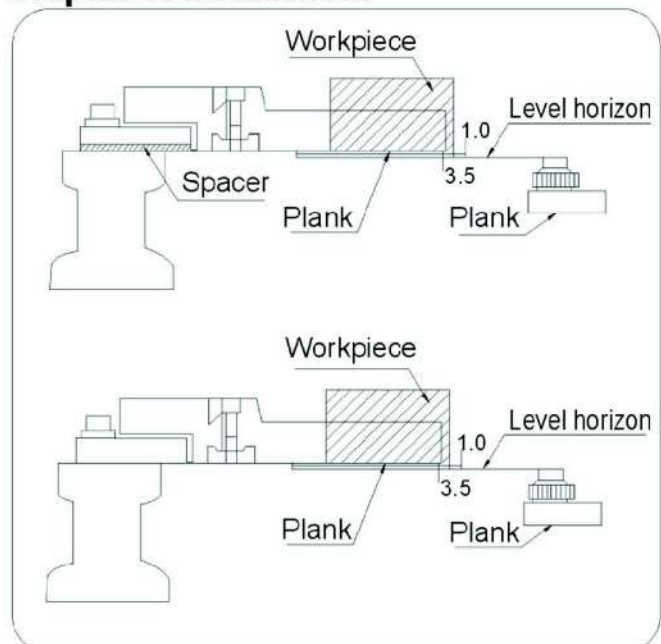

# Wire EDM Extensions Clamp

**53100**

**WST001**

**Leveling Base**



N.W. 1.8kg

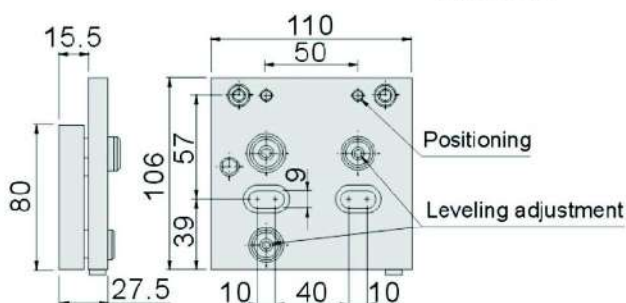

## Features :

- ▲ Suitable for using in WEDM machines and based on the processing needs, install with precision vise, V-block or parallel sets.
- ▲ Adopting high quality stainless steel (ASSAB-STAVAX) with Sub-zero Treatment after Vacuum Heat Treatment, stable and distortion free.
- ▲ Suitable for small, thin and round workpieces' application.
- ▲ 3-axis can be adjustable via applying hex wrench.
- ▲ Material: SUS440
- ▲ Hardness: HRC45°~ 55°
- ▲ Parallelism: within 0.003/100mm
- ▲ Squareness: within 0.005/100mm

**53105**

**WST080**

**Precision Vise**



N.W. 0.8kg

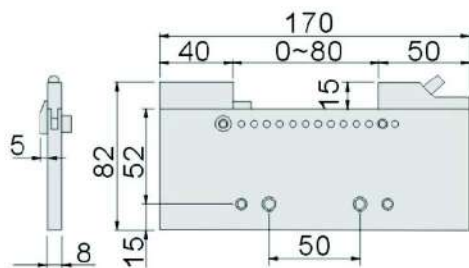

## Features :

- ▲ Adopting high quality stainless steel (ASSAB-STAVAX) with Sub-zero Treatment after Vacuum Heat Treatment, stable and distortion free.
- ▲ Can be installed with "Leveling base WST001", 3-axis can be adjustable via applying hex wrench.
- ▲ Material: SUS440
- ▲ Hardness: HRC45°~ 55°
- ▲ Parallelism: within 0.003/100mm
- ▲ Squareness: within 0.005/100mm

Application example  
with Leveling base



**53110**

**WST100**

**Precision Vise**



N.W. 2.0kg

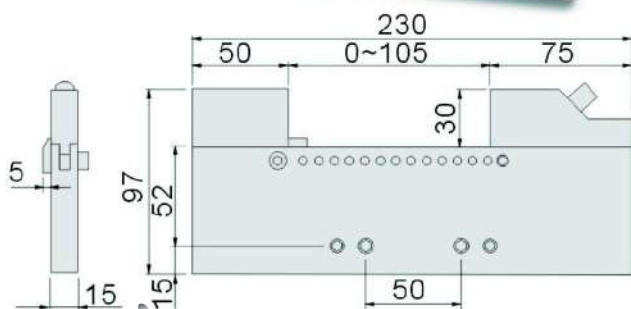

## Features :

- ▲ Adopting high quality stainless steel (ASSAB-STAVAX) with Sub-zero Treatment after Vacuum Heat Treatment, stable and distortion free.
- ▲ Can be installed with "Leveling base WST001", 3-axis can be adjustable via applying hex wrench.
- ▲ Material: SUS440
- ▲ Hardness: HRC45°~ 55°
- ▲ Parallelism: within 0.003/100mm
- ▲ Squareness: within 0.005/100mm

Application example  
with Leveling base



**53112****WAV35****Wire EDM Vise****Features :**

- ▶ Adopting high quality stainless steel with Sub-zero Treatment after Vacuum Heat Treatment, stable and distortion free.
- ▶ With manual screw design, it is suitable for small workpieces' application.
- ▶ High precision thanks to the special structure design.
- ▶ Hardness: HRC45°~ 55°
- ▶ Parallelism: within 0.003/100mm
- ▶ Squareness: within 0.005/100mm

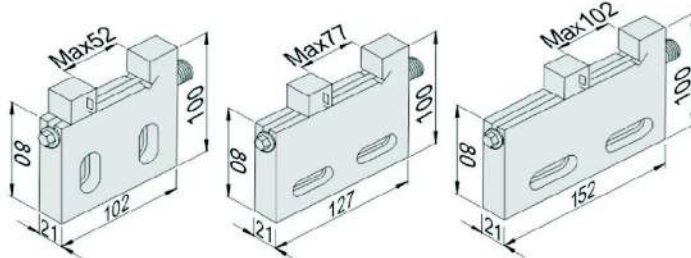
**53115****WAV****Wire EDM Vise****Features :**

- ▶ Adopting high quality stainless steel with Sub-zero Treatment after Vacuum Heat Treatment, stable and distortion free.
- ▶ With manual screw design, it is suitable for small workpieces' application.
- ▶ High precision thanks to the special structure design.
- ▶ Hardness: HRC45°~ 55°
- ▶ Parallelism: within 0.003/100mm
- ▶ Squareness: within 0.005/100mm

Unit:mm

Order No.	Model	Spec	Clamping range		N.W.
			Max.	Depth	
<b>53115-01</b>	WAV50	21x100x102	52	20	1.1kg
<b>53115-02</b>	WAV75	21x100x127	77	20	1.8kg
<b>53115-03</b>	WAV100	21x100x152	102	28	2.0kg

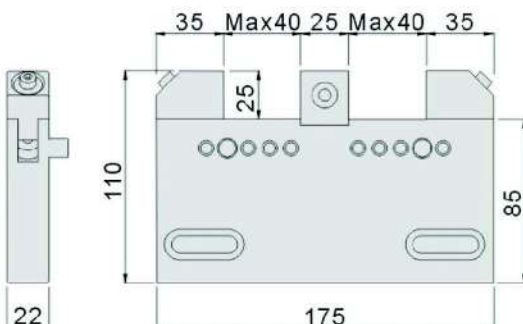
**53120****WBV40****Wire EDM Vise****Features :**

- ▶ Adopting high quality stainless steel with Sub-zero Treatment after Vacuum Heat Treatment, stable and distortion free.
- ▶ Quick dismantle function with 2 workpieces can be clamped at the same time.
- ▶ Lean angle design for the jaws, stronger clamping force and no floating. High water pressure resistance.
- ▶ Hardness: HRC45°~ 55°
- ▶ Hardness: HRC45°~ 55°
- ▶ Parallelism: within 0.003/100mm
- ▶ Squareness: within 0.005/100mm

Unit:mm

Spec	Clamping range			N.W.
	Max.	Thickness	Depth	
22x110x175	40	22	25	2.8kg

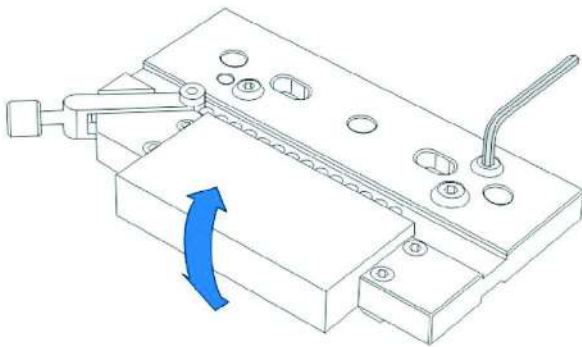
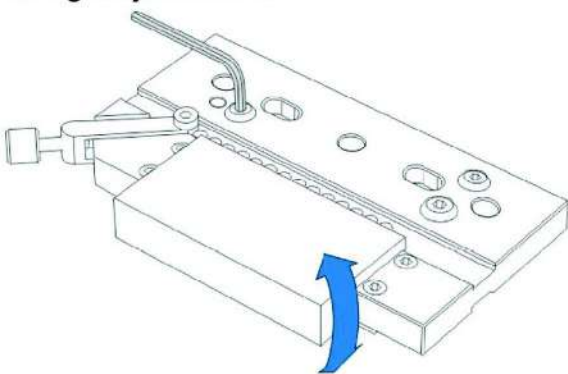
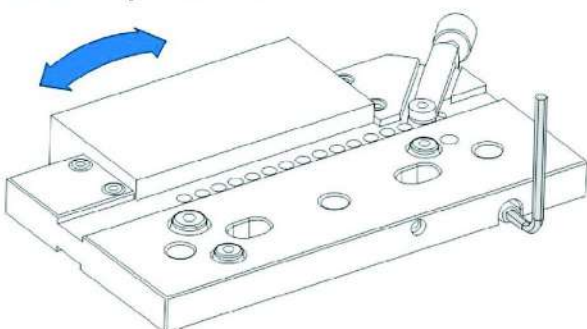

**53165****WEV280****Stainless Precision Vise For EDM****Leveling adjustment****Leveling adjustment****Parallel adjustment****Features :**

- ▶ Adopting high quality stainless steel (ASSAB STAVAX) with Sub-zero Treatment after Vacuum Heat Treatment, stable and distortion free.
- ▶ With 45° lock down design, workpiece anti-floating when clamp.
- ▶ 3-axis can be adjustable in this model.
- ▶ High water pressure resistance when clamping.
- ▶ Hardness: HRC45°~ 55°
- ▶ Parallelism: within 0.003/100mm
- ▶ Squareness: within 0.005/100mm

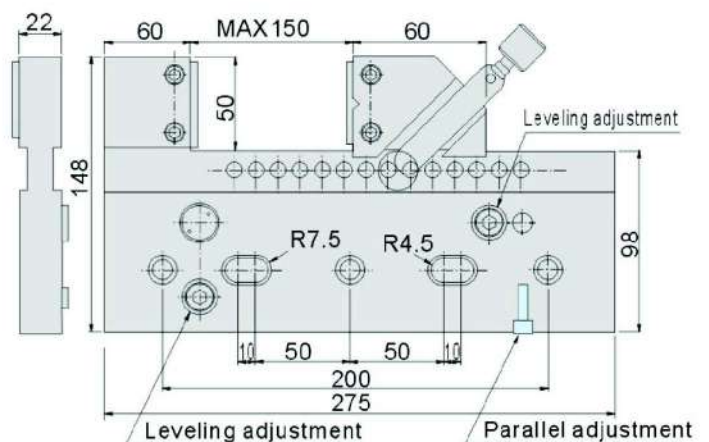

Spec	Clamping range			N.W.
	Max.	Thickness	Depth	
22x148x275	150	22	50	5.5kg

Unit:mm

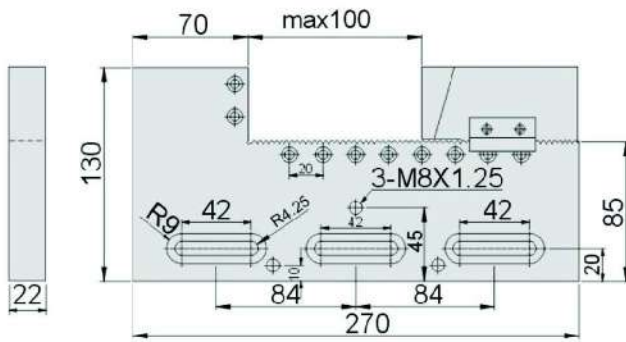

**53135****WPV100****Stainless Precision Vise For EDM****Features :**

- ▶ Adopting high quality stainless steel (ASSAB STAVAX) with Sub-zero Treatment after Vacuum Heat Treatment, stable and distortion free.
- ▶ With 45° lock down design, workpiece anti-floating when clamp.
- ▶ Hardness: HRC45°~ 55°
- ▶ Parallelism: within 0.003/100mm
- ▶ Squareness: within 0.005/100mm

Spec	Clamping range			N.W.
	Max.	Thickness	Depth	
22x130x270	100	22	45	5.0kg

Unit:mm

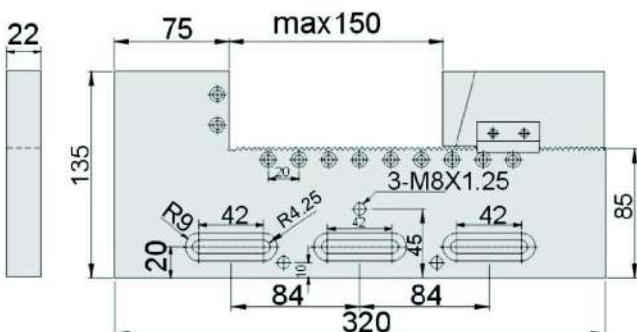
**WIRE EDM  
EXTENSIONS CLAMP**
**53140****WPV150****Stainless Precision Vise For EDM****Features :**

- ▶ Adopting high quality stainless steel (ASSAB STAVAX) with Sub-zero Treatment after Vacuum Heat Treatment, stable and distortion free.
- ▶ With 45° lock down design, workpiece anti-floating when clamp.
- ▶ Hardness: HRC45°~ 55°
- ▶ Parallelism: within 0.003/100mm
- ▶ Squareness: within 0.005/100mm

Spec	Clamping range			N.W.
	Max.	Thickness	Depth	
22x135x320	150	22	50	5.6kg

Unit:mm



# Wire EDM Extensions Clamp

**53145**

WPV

Stainless Precision Vise For EDM



## Features :

- ▶ Adopting high quality stainless steel (ASSAB STAVAX) with Sub-zero Treatment after Vacuum Heat Treatment, stable and distortion free.
- ▶ With 45° lock down design, workpiece anti-floating when clamp.
- ▶ 3-axis can be adjustable in this model.
- ▶ High water pressure resistance when clamping.
- ▶ Hardness: HRC45°~ 55°
- ▶ Parallelism: within 0.003/100mm
- ▶ Squareness: within 0.005/100mm

### Leveling adjustment

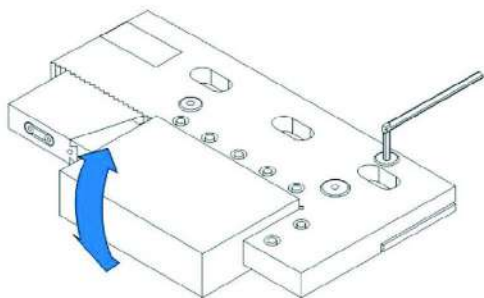

### Leveling adjustment

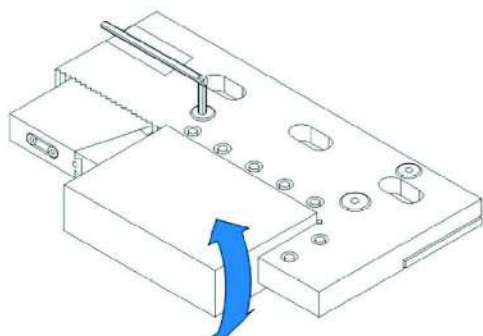

### Parallel adjustment

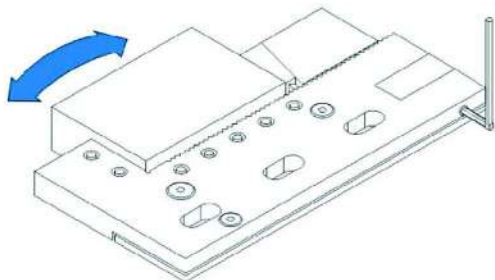

### Graphic of installation

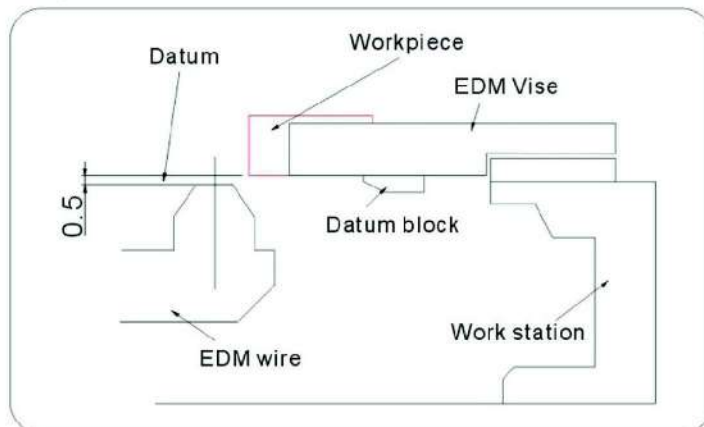

### WPV320 spec

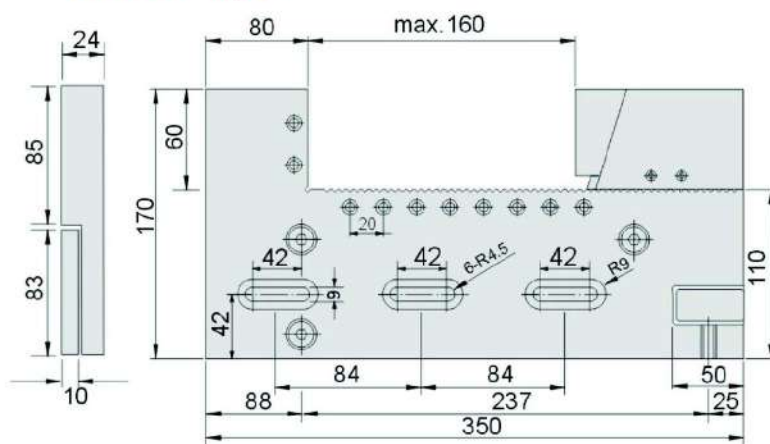

Unit:mm

Order No.	Model	Spec	Clamping range		N.W.
			Max.	Depth	
53145-01	WPV280	24x170x270	100	50	5.5kg
53145-02	WPV320	24x170x350	160	60	8.6kg

WIRE EDM EXTENSIONS CLAMP

**53148****WPV****Stainless Precision Vise For EDM**

WPV300



WPV240

X, Y, Z axis fine-tuning illustration

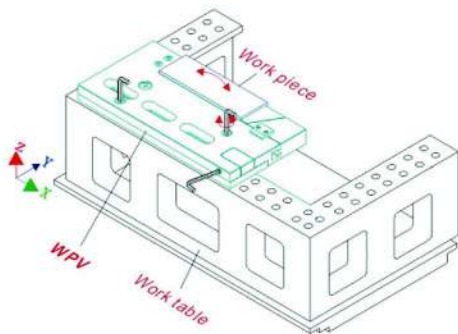

1. left &amp; right

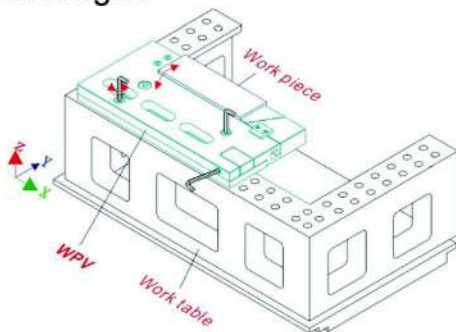

2. Up &amp; down

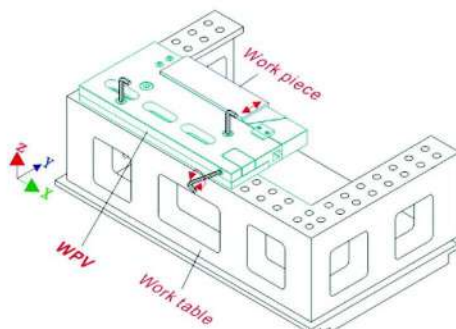

3. back &amp; forward

**Features :**

- ▶ Adopting stainless steel with Sub-zero Treatment after Vacuum Heat Treatment, stable and distortion free.
- ▶ With X, Y, and Z axis fine-tuning function.
- ▶ Material: SUS440
- ▶ Hardness: HRC45°~ 55°
- ▶ Parallelism: within 0.003/100mm
- ▶ Squareness: within 0.005/100mm

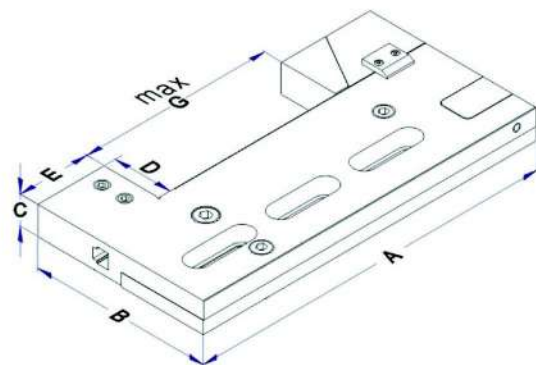

Installation illustration

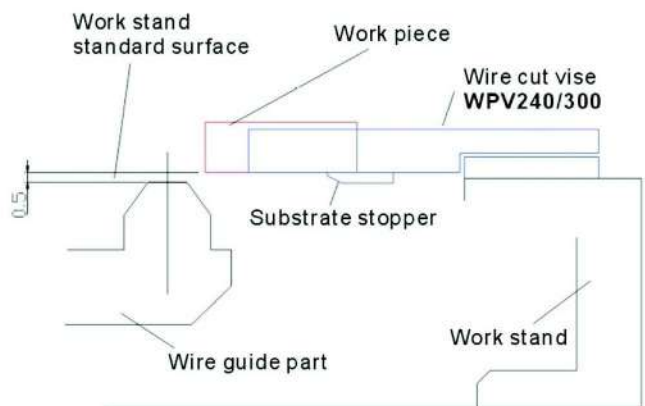

Unit:mm

Order No.	Model	A	B	C	D	E	G	N.W.
53148-01	WPV240	245	160	24	50	55	100	5.4kg
53148-02	WPV300	300	160	24	50	60	150	7.8kg

**WIRE EDM  
EXTENSIONS CLAMP**

# Wire EDM Extensions Clamp

**53150**

**WEV100**

**Stainless Precision Vise For EDM**

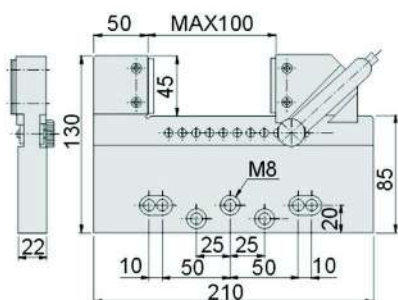

## Features :

- ▶ Adopting high quality stainless steel (ASSAB STAVAX) with Sub-zero Treatment after Vacuum Heat Treatment, stable and distortion free.
- ▶ With 45° lock down design, workpiece anti-floating when clamp.
- ▶ Hardness: HRC45°~ 55°
- ▶ Parallelism: within 0.003/100mm
- ▶ Squareness: within 0.005/100mm

Unit:mm

Spec	Clamping range			N.W.
	Max.	Thickness	Depth	
22x130x210	100	22	45	3.0kg

**53155**

**WEV150**

**Stainless Precision Vise For EDM**

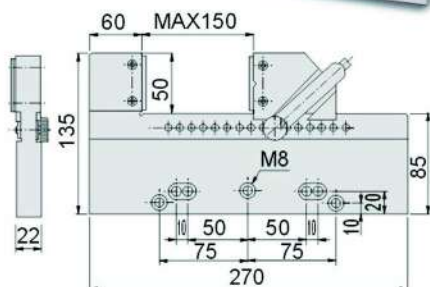

## Features :

- ▶ Adopting high quality stainless steel (ASSAB STAVAX) with Sub-zero Treatment after Vacuum Heat Treatment, stable and distortion free.
- ▶ With 45° lock down design, workpiece anti-floating when clamp.
- ▶ Hardness: HRC45°~ 55°
- ▶ Parallelism: within 0.003/100mm
- ▶ Squareness: within 0.005/100mm

Unit:mm

Spec	Clamping range			N.W.
	Max.	Thickness	Depth	
22x135x270	150	22	50	4.0kg

**53160**

**WEV250**

**Stainless Precision Vise For EDM**

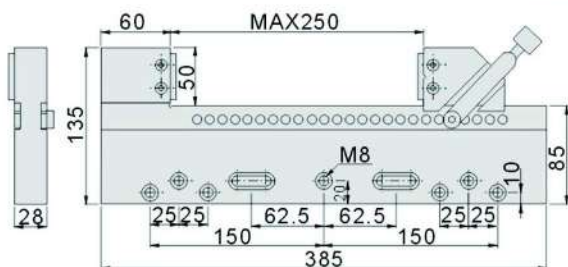

## Features :

- ▶ Adopting high quality stainless steel (ASSAB STAVAX) with Sub-zero Treatment after Vacuum Heat Treatment, stable and distortion free.
- ▶ With 45° lock down design, workpiece anti-floating when clamp.
- ▶ Hardness: HRC45°~ 55°
- ▶ Parallelism: within 0.003/100mm
- ▶ Squareness: within 0.005/100mm

Unit:mm

Spec	Clamping range			N.W.
	Max.	Thickness	Depth	
28x135x385	250	28	50	5.5kg

WIRE EDM EXTENSIONS CLAMP

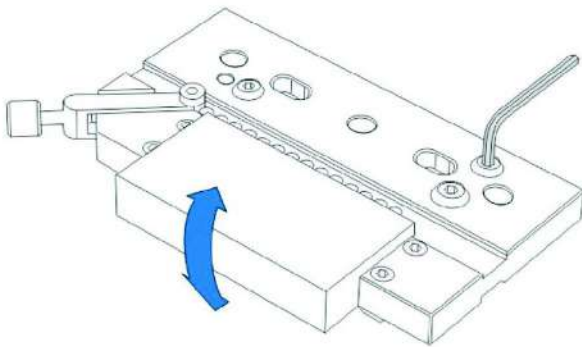
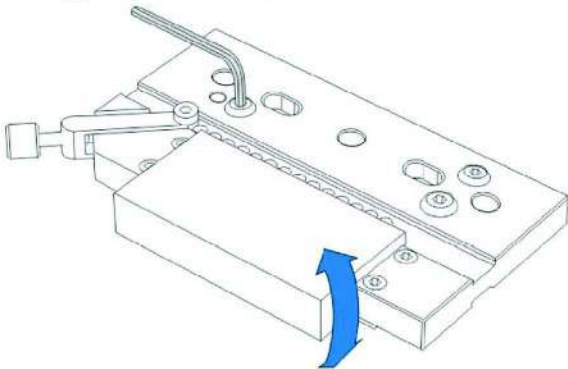
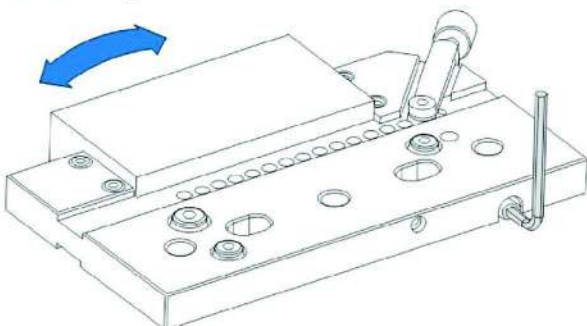
**53165****WEV280****Stainless Precision Vise For EDM****Leveling adjustment****Leveling adjustment****Parallel adjustment****Features :**

- ▶ Adopting high quality stainless steel (ASSAB STAVAX) with Sub-zero Treatment after Vacuum Heat Treatment, stable and distortion free.
- ▶ With 45° lock down design, workpiece anti-floating when clamp.
- ▶ 3-axis can be adjustable in this model.
- ▶ High water pressure resistance when clamping.
- ▶ Hardness: HRC45°~ 55°
- ▶ Parallelism: within 0.003/100mm
- ▶ Squareness: within 0.005/100mm

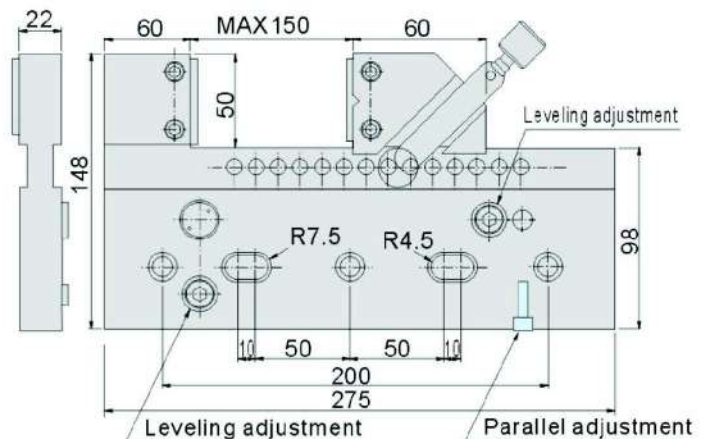

Spec	Clamping range			N.W.
	Max.	Thickness	Depth	
22x148x275	150	22	50	5.5kg

Unit:mm



# Wire EDM Extensions Clamp

**53168**

**WFV100**

**Stainless Precision Vise For EDM**



## Features :

- ▶ Adopting high quality stainless steel (ASSAB STAVAX) with Sub-zero Treatment after Vacuum Heat Treatment, stable and distortion free.
- ▶ With screw bar design, workpieces can be easily and rapidly clamped to any suitable sizes.
- ▶ Hardness: HRC45°~ 55°
- ▶ Parallelism: within 0.003/100mm
- ▶ Squareness: within 0.005/100mm

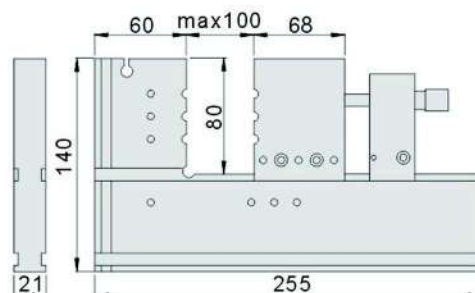

**53170**

**WHV**

**Stainless Precision Vise For EDM**



## Features :

- ▶ Adopting high quality stainless steel (ASSAB STAVAX) with Sub-zero Treatment after Vacuum Heat Treatment, stable and distortion free.
- ▶ With screw bar design, workpieces can be easily and rapidly clamped to any suitable sizes.
- ▶ Hardness: HRC45°~ 55°
- ▶ Parallelism: within 0.003/100mm
- ▶ Squareness: within 0.005/100mm

### Graphic of installation

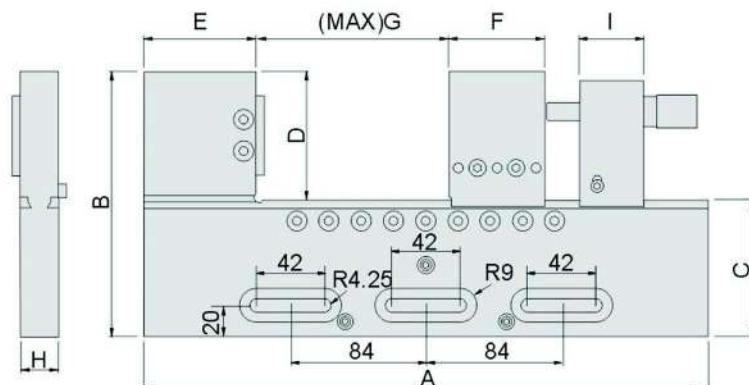
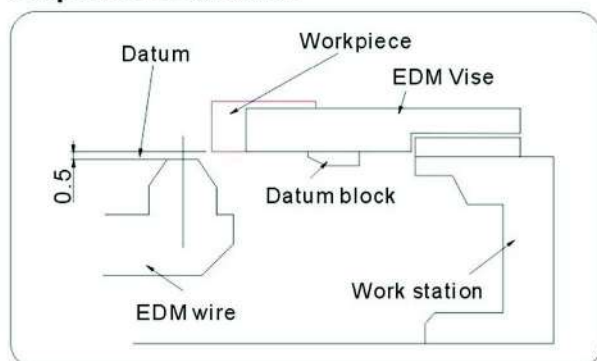

Unit:mm

Order No.	Model	A	B	C	D	E	F	G	H	I	N.W.
53170-01	WHV100	275	135	85	50	60	60	120	24	35	5.5kg
53170-02	WHV150	350	145	85	60	70	60	180	24	35	7.5kg

**53175****WHV****Stainless Precision Vise For EDM****WHV260****Features :**

- ▶ Adopting high quality stainless steel (ASSAB STAVAX) with Sub-zero Treatment after Vacuum Heat Treatment, stable and distortion free.
- ▶ With screw bar design, workpieces can be easily and rapidly clamped to any suitable sizes.
- ▶ Hardness: HRC45°~55°
- ▶ Parallelism: within 0.003/100mm
- ▶ Squareness: within 0.005/100mm

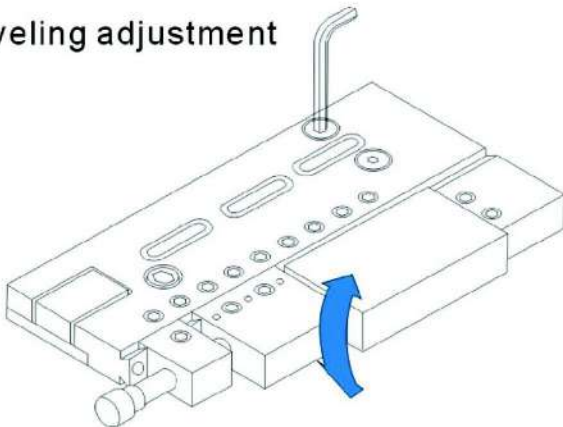
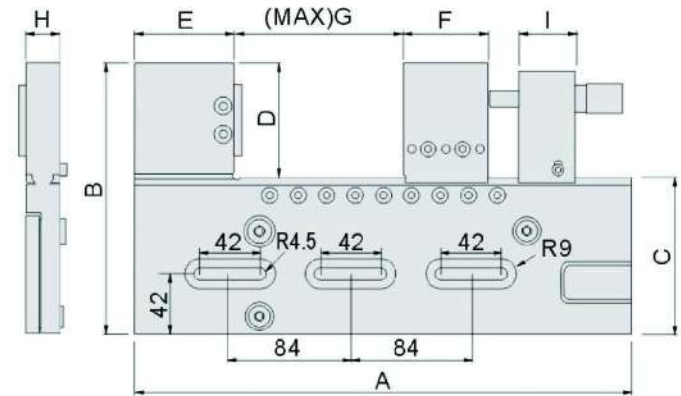
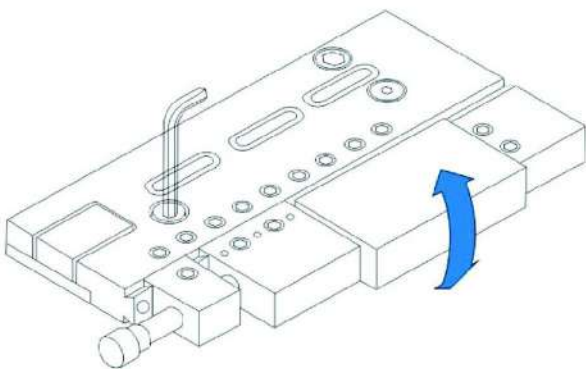
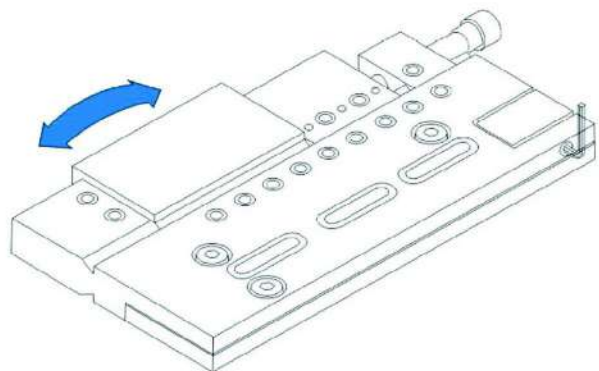
**WHV350****Leveling adjustment****Leveling adjustment****WHV350****Parallel adjustment**

Unit:mm

Order No.	Model	A	B	C	D	E	F	G	H	I	N.W.
<b>53175-01</b>	WHV260	275	160	110	50	60	60	120	24	35	7.0kg
<b>53175-02</b>	WHV350	350	170	110	60	70	60	180	24	35	9.0kg



# Wire EDM Extensions Clamp

**53180** WCV280 Stainless Precision Vise For EDM



## Features :

- ▶ Adopting high quality stainless steel (ASSAB STAVAX) with Sub-zero Treatment after Vacuum Heat Treatment, stable and distortion free.
- ▶ With 45°aw design, workpiece anti-floating when clamp.
- ▶ Adopting ball bearings and make 3-axis adjustment much more efficient.
- ▶ High water pressure resistance when clamping.
- ▶ Hardness: HRC45°~ 55°
- ▶ Parallelism: within 0.003/100mm
- ▶ Squareness: within 0.005/100mm

WIRE EDM EXTENSIONS CLAMP

Leveling adjustment

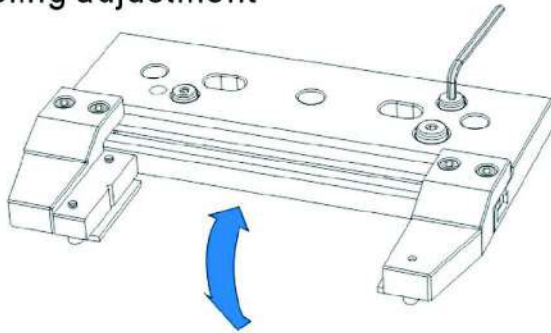

Leveling adjustment

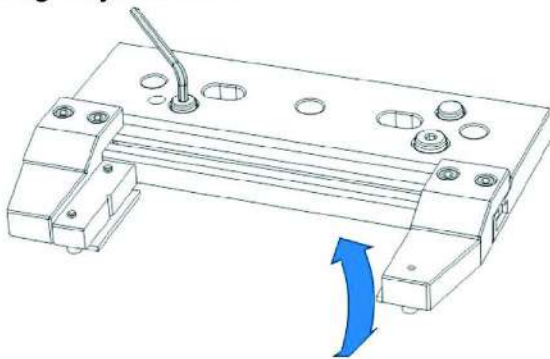

Parallel adjustment

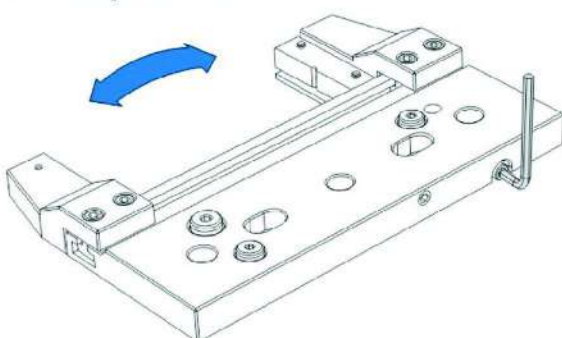

## Application example

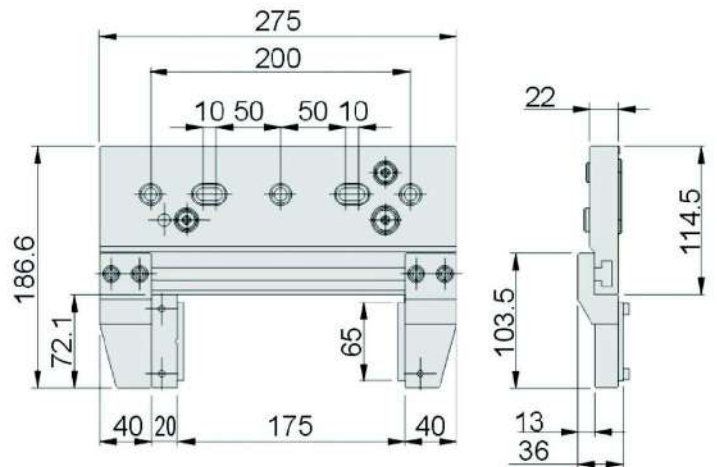
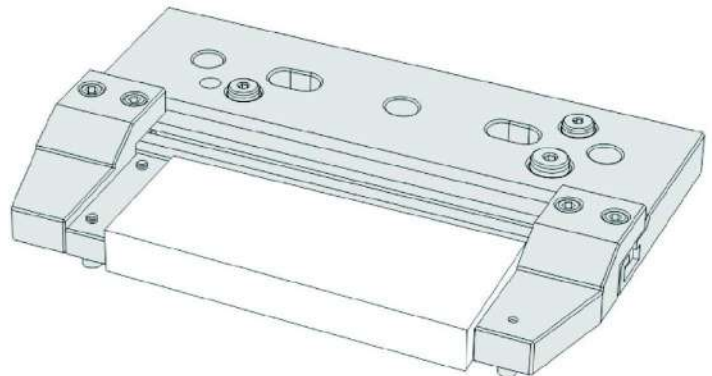

Unit:mm

Spec	Clamping range			N.W.
	Max.	Thickness	Depth	
36x186.6x275	175	22	72.1	6kg

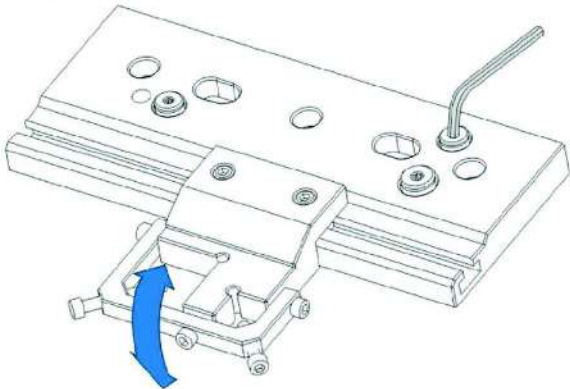
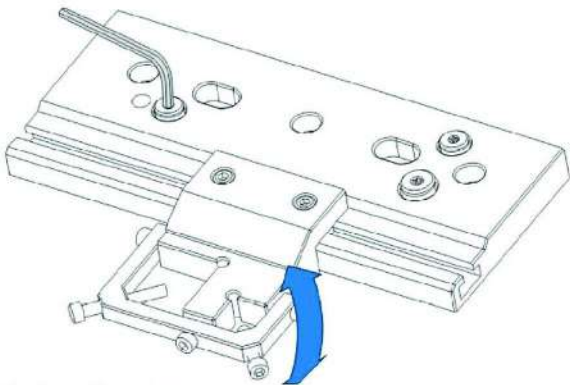
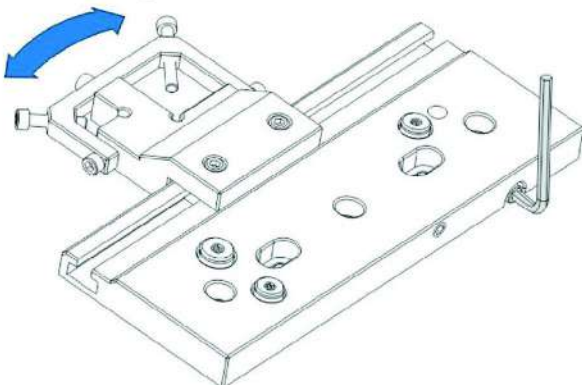
**53185****WDV280****Stainless Precision Vise For EDM****Leveling adjustment****Leveling adjustment****Parallel adjustment****Features :**

- ▲ Adopting high quality stainless steel (ASSAB STAVAX) with Sub-zero Treatment after Vacuum Heat Treatment, stable and distortion free.
- ▲ With 45° Jaw design, workpiece anti-floating when clamp.
- ▲ Adopting ball bearings and make 3-axis adjustment much more efficient.  
High water pressure resistance when clamping.
- ▲ Clamping range for round workpiece:  $\varnothing 3 \sim \varnothing 38$  mm
- ▲ In small V groove:  $\varnothing 3 \sim \varnothing 20$  mm
- ▲ In large V groove:  $\varnothing 10 \sim \varnothing 38$  mm
- ▲ Hardness: HRC45°~ 55°
- ▲ Parallelism: within 0.003/100mm
- ▲ Squareness: within 0.005/100mm

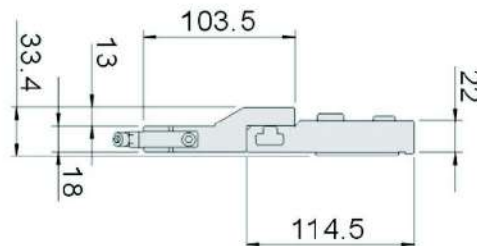
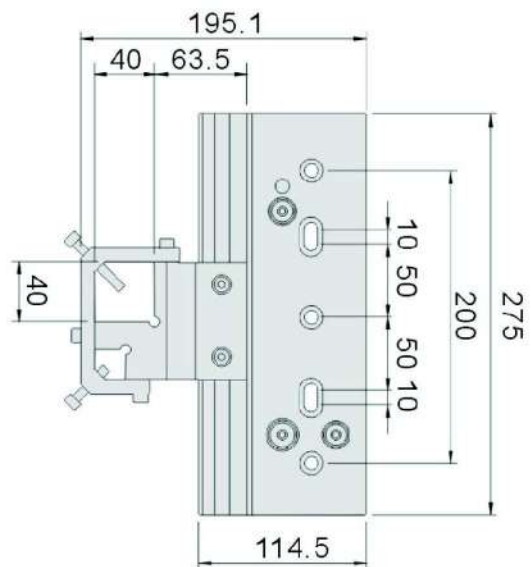

Unit:mm

Spec	Clamping range		N.W.
	Small V groove	Large V groove	
33.4x195.1x275	$\varnothing 3 \sim \varnothing 20$	$\varnothing 10 \sim \varnothing 38$	5.7kg

WIRE EDM  
EXTENSIONS CLAMP

# Electrode Vise

Material : SUS440

Parallelism: within 0.003mm/100mm

Hardness: HRC48°~55°

Squareness: within 0.005mm/100mm

Unit:mm

**53300** VH20



N.W. 0.5kg

## Features :

- ▶ A delicate vise and suitable for clamping precision workpiece used in EDM Machine.

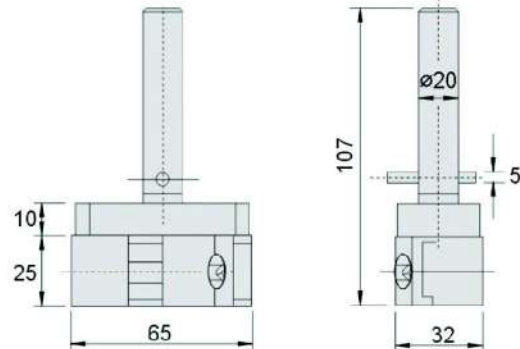

**53310** VW20



N.W. 0.8kg

## Features :

- ▶ Two way clamping and suitable for small and precision work in EDM Machine.

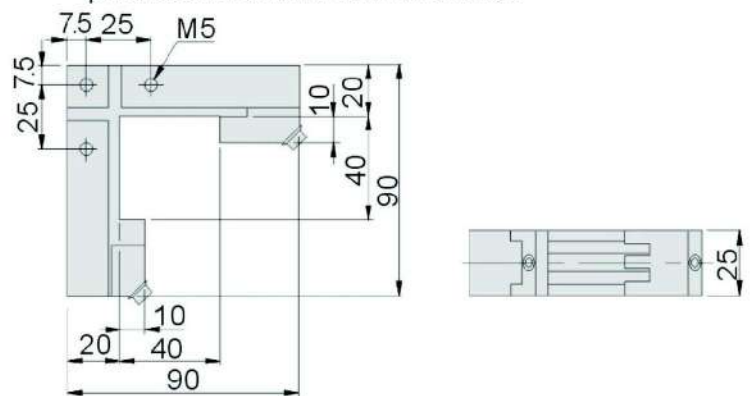

**53320** EVH20



N.W. 0.7kg

## Features :

- ▶ Compact version precision vise, suitable for small precision workpiece.
- ▶ Used in EDM machine.

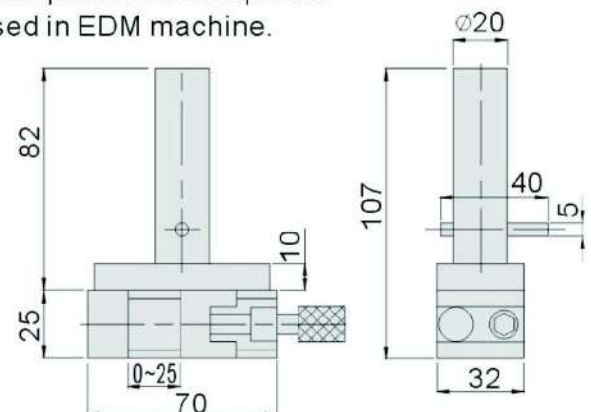

Material :SUS440 Parallelism:within 0.003mm/100mm  
Hardness:HRC48°~55° Squareness:within 0.005mm/100mm

Unit:mm

## 53330 EVH50



N.W. 1.1kg

### Features :

- ▶ Compact version precision vise, suitable for small precision workpiece.
- ▶ Used in EDM machine.

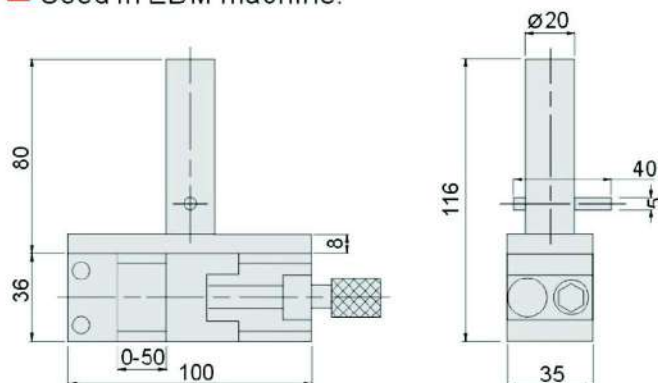

## 53340 EVR40



N.W. 1.2kg

### Features :

- ▶ Compact version precision vise, suitable for small precision workpiece.
- ▶ Used in EDM machine.

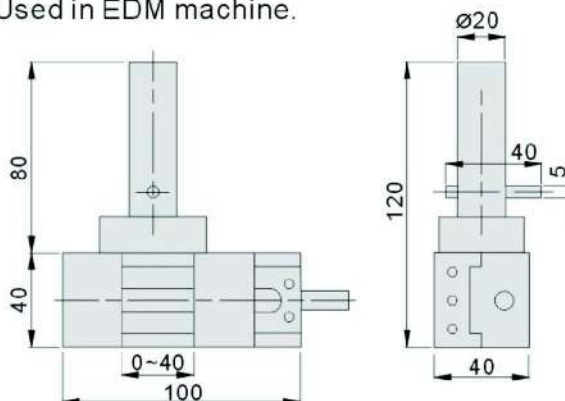

ELECTRODE VISE

# Stainless Tool Maker Vise

## 53342 VLS Stainless Tool Maker Vise



### Features :

- ▶ Suitable for EDM, milling, and precision grinding work.

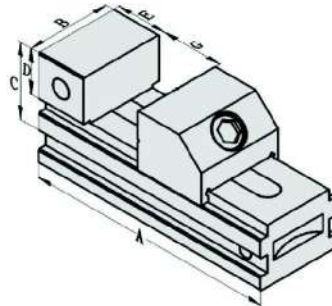

Material :SUS440

Hardness:HRC45°~55°

Parallelism:within 0.003mm/100mm

Squareness:within 0.005mm/100mm

Unit:mm

Order No.	Model	A	B	C	D	E	G	N.W.
53342-01	VLS15	100	35	40	20	25	0~45	1.0kg
53342-02	VLS20	140	48	50	25	25	0~75	2.0kg
53342-03	VLS25	172	63	60	30	30	0~90	3.3kg
53342-04	VLS30	190	73	70	35	35	0~100	4.3kg
53342-05	VLS40	230	98	80	40	40	0~125	9.8kg

ELECTRODE VISE

## 53346 VHS Stainless Tool Maker Vise

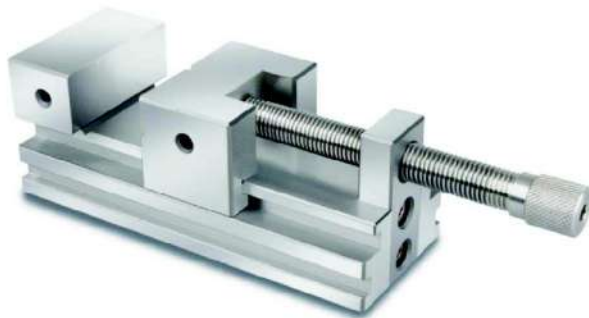

### Features :

- ▶ Suitable for EDM, milling, and precision grinding work.

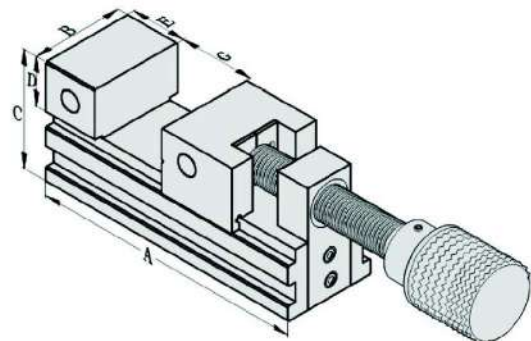

Material :SUS440

Hardness:HRC45°~55°

Parallelism:within 0.003mm/100mm

Squareness:within 0.005mm/100mm

Unit:mm

Order No.	Model	A	B	C	D	E	G	N.W.
53346-01	VHS20	140	48	55	25	25	0~70	2.60kg
53346-02	VHS25	172	63	69	30	30	0~85	4.80kg
53346-03	VHS30	190	73	78	35	35	0~100	6.60kg
53346-04	VHS40	230	98	92	40	40	0~125	13.0kg

Material :SUS440

Parallelism:within 0.003mm/100mm

Hardness:HRC48°~55°

Squareness:within 0.005mm/100mm

Unit:mm

### 53350 EVJ10

It can be used with positioning plate of EROWA and System 3R.

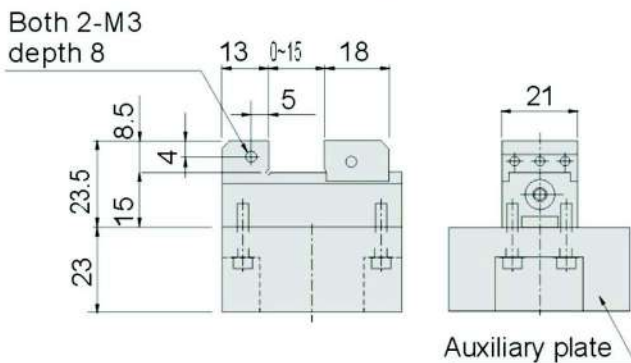
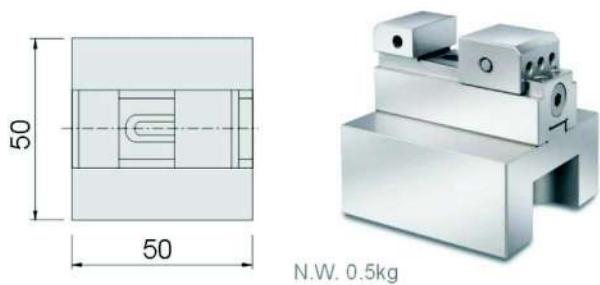

### 53360 EVL10

It can be used with positioning plate of EROWA and System 3R.

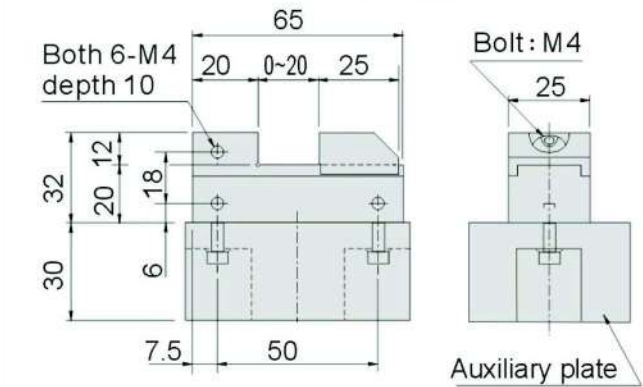
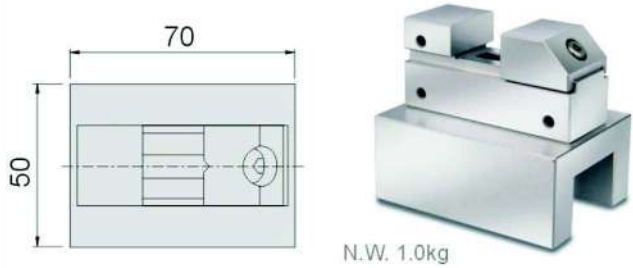

### 53370 ESV45

It can be used with positioning plate of EROWA and System 3R.

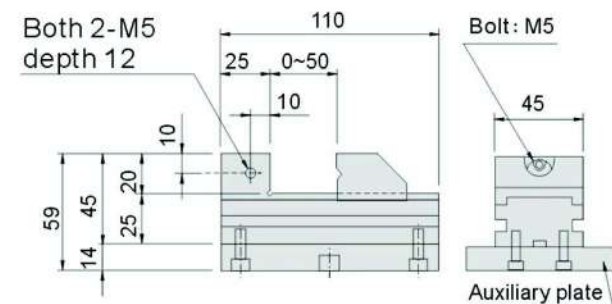
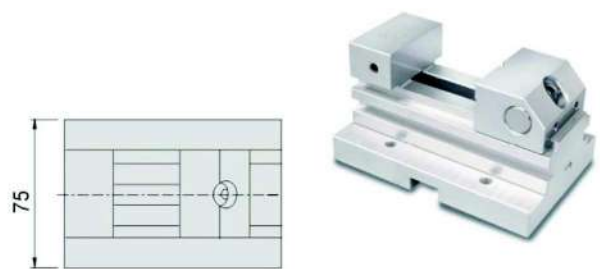

### 53380 ESV70

It can be used with positioning plate of EROWA and System 3R.

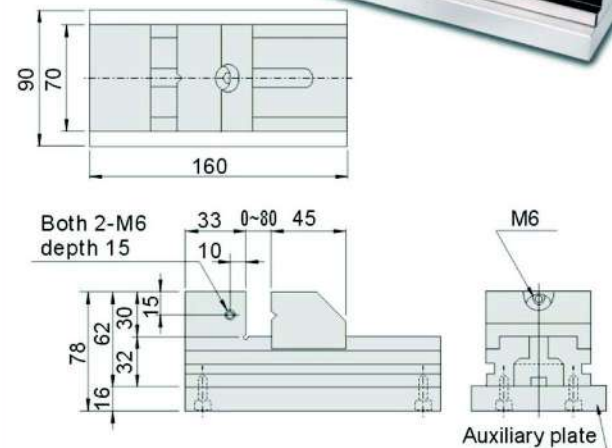

ELECTRODE VISE

# Electrode Vise

Material :SUS440

Parallelism:within 0.003mm/100mm

Hardness:HRC48°~55°

Squareness:within 0.005mm/100mm

Unit:mm

## 53390

### EDSU60

- It can be used with positioning plate of EROWA (ER-009214)and System 3R (3R-651.7E-P).

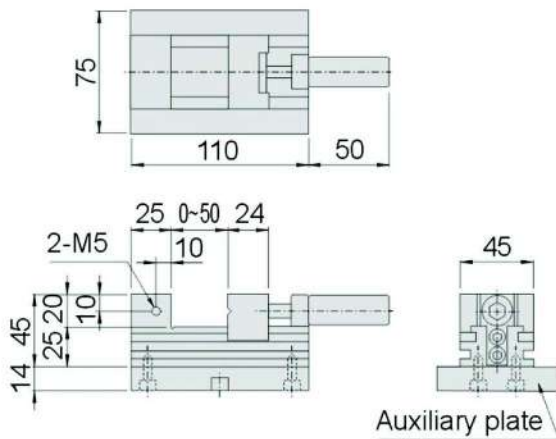

Auxiliary plate

## 53400

### EDSU80

- It can be used with positioning plate of EROWA (ER-011599)and System 3R (3R-601.7E-P).

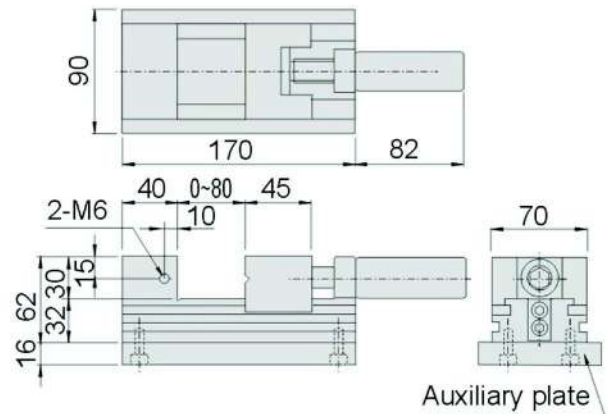

Auxiliary plate

## 53410

### EMC75

- It can be used with positioning plate of EROWA (ER-009214)and System 3R (3R-651.7E-P).

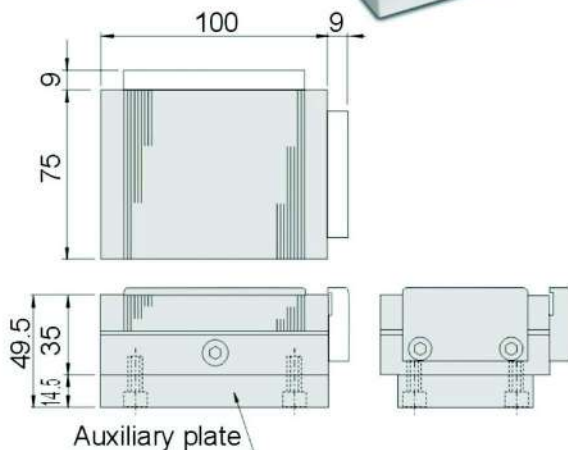

Auxiliary plate

## 53420

### EMC75S

- It can be used with positioning plate of EROWA (ER-009214)and System 3R (3R-651.7E-P).

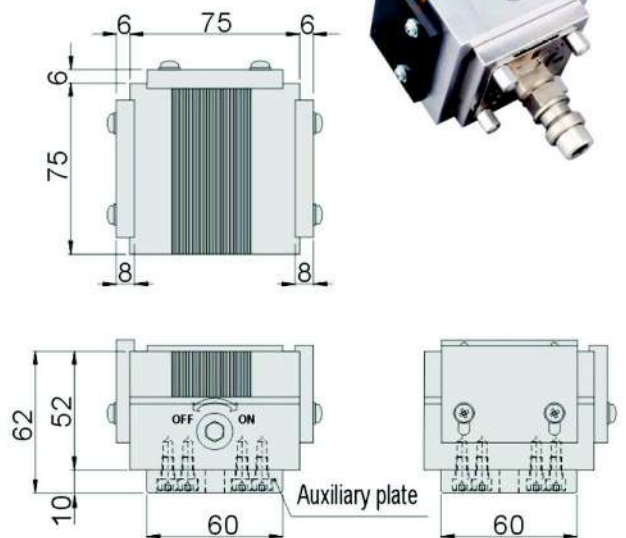

Auxiliary plate

Breakthrough thinking of high precision systems for efficiency working environment.

Creating better processing environment by applying various modulisation.

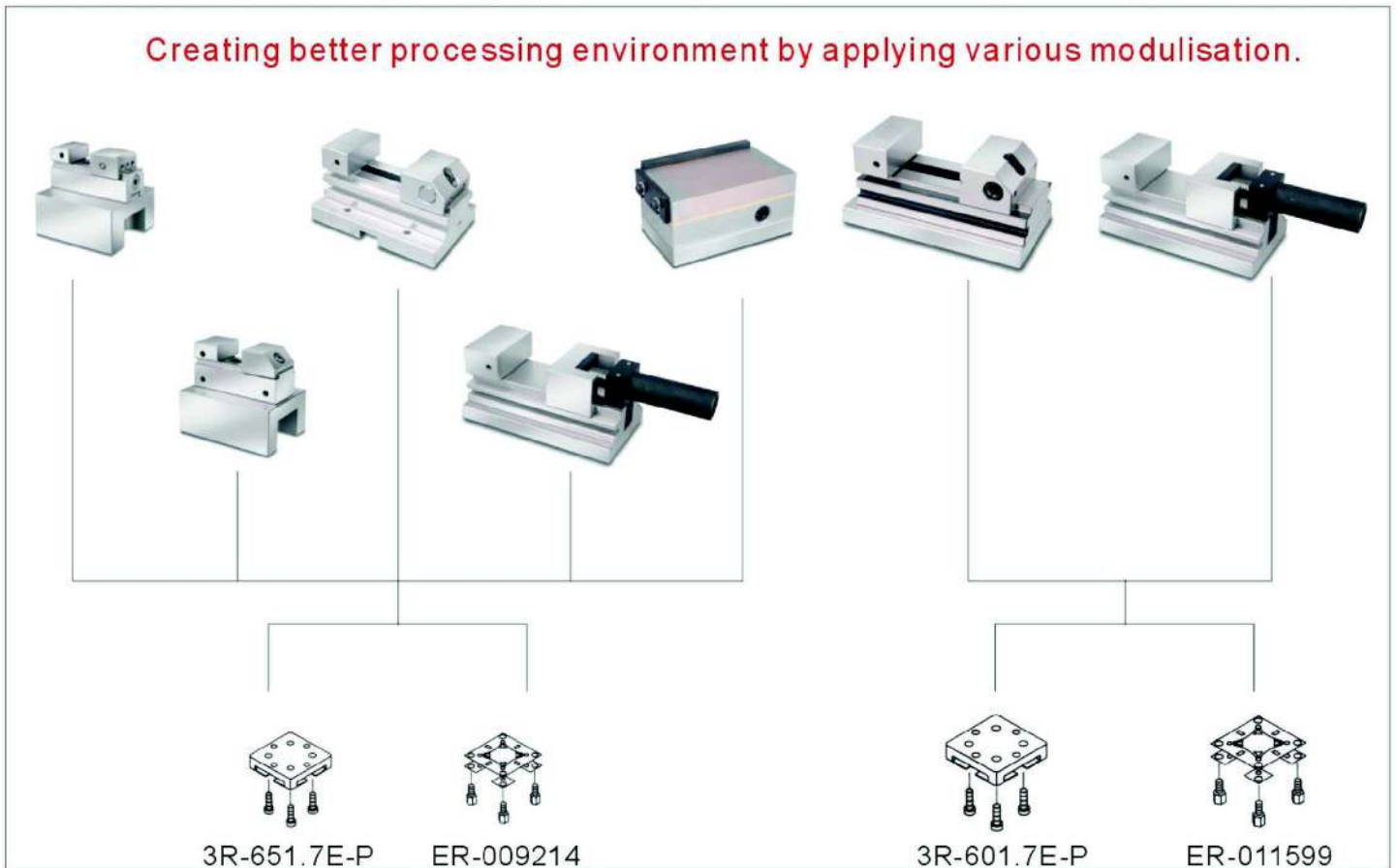

ELECTRODE VISE

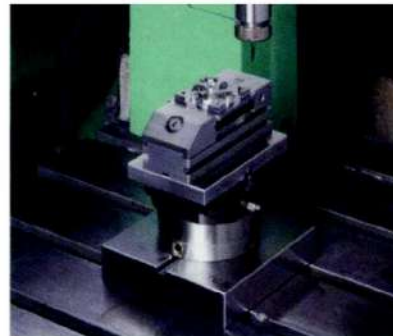

EDM

EDM

Grinding

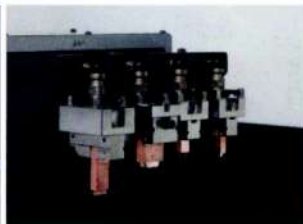

## Features :

- ▶ Simple: It can be applied straight away after purchasing.
- ▶ Economic: More cost effective and easy to used in parallel.
- ▶ Compatibility: Same material applied with EROWA and System 3R.



# Sine Plate

## 54080 SP Sine Plate



### Features :

- ▶ Tapped holes in top plate 3" x 6", 5" x 6" for fixing workpieces.
- ▶ Squareness within 0.0002"
- ▶ Parallelism within 0.0002" / 4".
- ▶ Center distance of rolls within 0.0002".
- ▶ Adjustable angle 0-60°

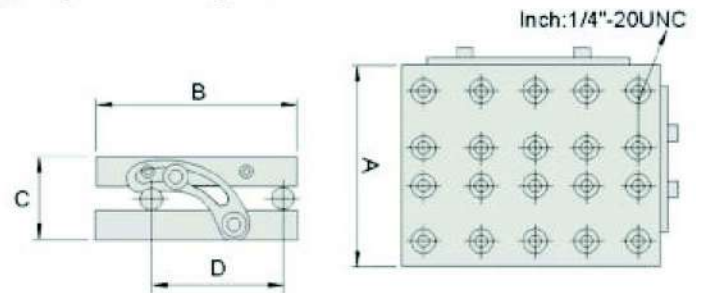

Unit: Inch

Order No.	Model	A	B	C	D	N.W.
54080-15	SP36	3.228	6	2.205	5	4.2kg
54080-25	SP56	5	6	2.362	5	7kg

MAGNETIC TOOLS

## 54090 SP Sine Plate



### Features :

- ▶ Tapped holes in top plate 6" x 6", 4" x 7" for fixing workpieces.
- ▶ Squareness within 0.005mm (0.0002")
- ▶ Parallelism within 0.005mm (0.0002") / 100mm
- ▶ Center distance of rolls within 0.005mm. (0.0002")
- ▶ Adjustable angle 0-60°.

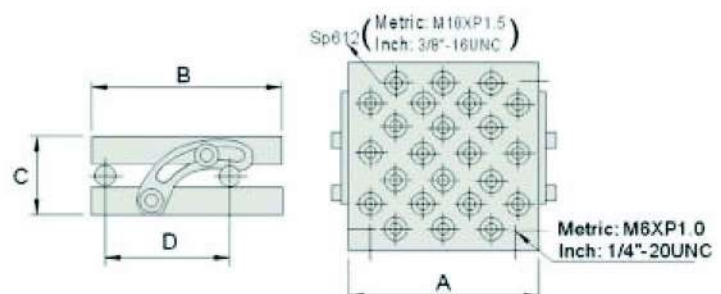

Metric / Inch

Order No.	Model	A	B	C	D	N.W.			
54090-10	SP47	175	7	100	4	60			
54090-15		7	100	4	60	2.362			
54090-20	SP66	150	6	150	6	60			
54090-25		6	150	6	60	2.362			
54090-30	SP612	300	12	150	6	60			
54090-35		12	150	6	60	2.362			
							75	3	6.5kg
							100	5	8.1kg
							100	5	15.8kg

**54100****CSP****Compound Sine Plate**

### Features :

- ▶ Widely applied on grinding or milling machines with compound angle adjustable.
- ▶ Made of quality steel, hardened to 55° - 58°.
- ▶ Parallelism within 0.005mm(0.0002") / 100mm
- ▶ Center distance of rolls within 0.005mm (0.0002").
- ▶ Adjustable angle 0-60°.

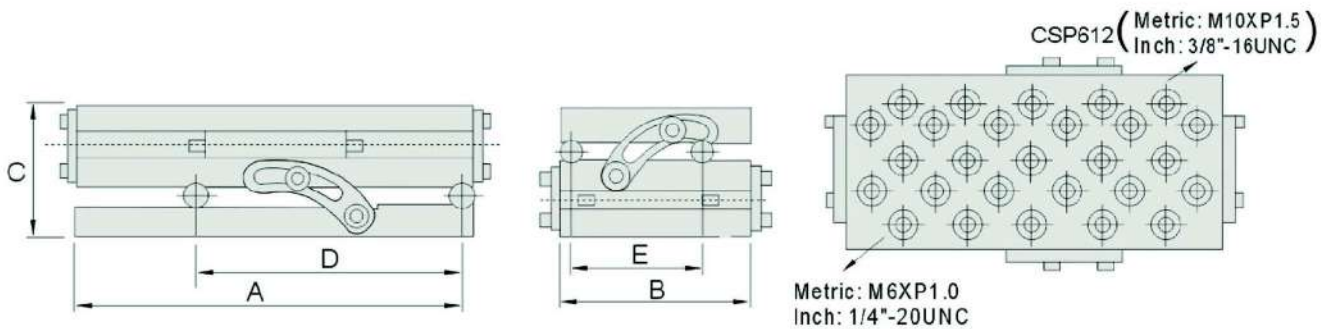

Metric	Inch
--------	------

Order No.	Model	A	B	C	D	E	N.W.
54100-10	CSP47	175	100	100	100	75	9.7kg
54100-15		7	4	4	5	3	
54100-20	CSP66	150	150	100	100	100	12.2kg
54100-25		6	6	4	5	5	
54100-30	CSP612	300	150	100	200	100	23.4kg
54100-35		12	6	4	10	5	



# Measuring Tool

**55000**

AP25/30/46

Adjustable Angle Plate

PAT: 192623  
ZL 02 2 42472.5



Applying on milling machine.



Mark out on a workpiece

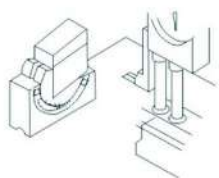

## Features:

- ▲ Made of tool steel.
- ▲ Suitable for placing on large vise for angular processing needs.
- ▲ Adjustable angle 30°~ 0°~ 60°

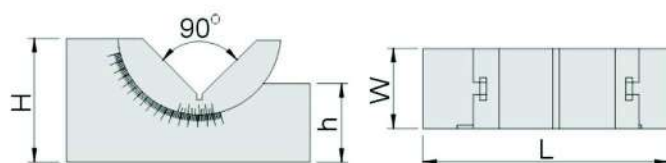

Unit:mm

Order No.	Model	L	W	H	h	N.W.
55000-25	AP25	75	25	36	25	0.4kg
55000-30	AP30	102	30	49	30	0.9kg
55000-46	AP46	102	46	49	30	1.4kg

**55004**

A2~6

B Type Vee Blocks

## Features:

- ▲ Sold in pairs.
- ▲ V groove accuracy within 0.005mm, suitable for inspecting concentricity.

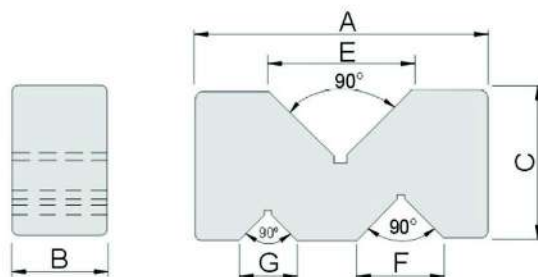

Unit:mm

Order No.	Model	A	B	C	E	F	G	N.W.
55004-02	A2	50	19	24	24	17	13	0.3kg
55004-03	A3	75	24	35	37	24	16	0.8kg
55004-04	A4	100	33	52	50	30	20	2.2kg
55004-05	A5	125	44	69	63	37	26	5.0kg
55004-06	A6	150	50	80	75	45	30	7.8kg

**55006**

PV100

**V Blocks with C Clamp**

N.W. 2.8kg

**Features:**

- ▶ Sold in pairs.
- ▶ Precisely ground and high accuracy of V groove.
- ▶ Suitable for processing steel rod or testing concentricity.
- ▶ Clamping range  $\varnothing 3 \sim \varnothing 20$
- ▶ Height deviation: 0.005mm
- ▶ Squareness: 0.005mm
- ▶ V groove acc. within 0.005mm

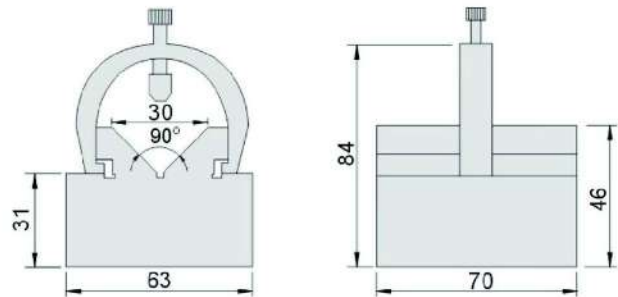
**55008**

PV150/200

**V Blocks with C Clamp****Features:**

- ▶ Suitable for machining, EDM, testing purposes.
- ▶ Clamping range:  $\varnothing 3.5\text{mm} \sim \varnothing 33\text{mm}$  (PV150),  
 $\varnothing 3.5\text{mm} \sim \varnothing 41\text{mm}$  (PV200)
- ▶ V groove parallelism 0.005mm / 100mm
- ▶ Squareness within 0.005mm / 100mm
- ▶ Material: SKS3 , HRC56°~ 60°
- ▶ Sold in pairs.

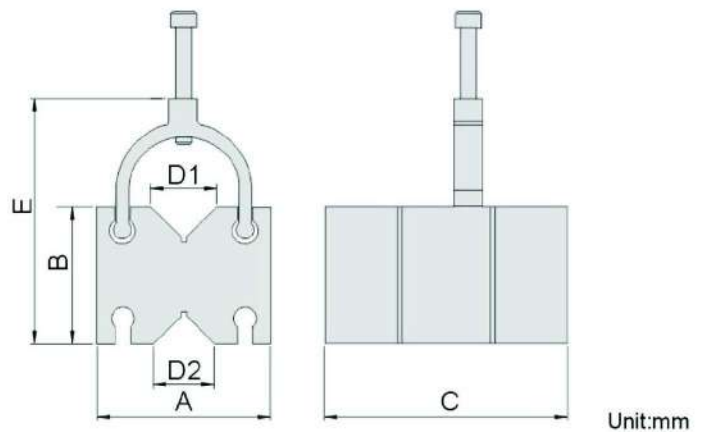

Unit:mm

Order No.	Model	A	B	C	D1	D2	E	N.W.
55008-01	PV150	64	45	70	29	24	90	1.3kg
55008-02	PV200	90	70	125	34	31	125.5	5.2kg



**55006**

PV100

**V Blocks with C Clamp**

N.W. 2.8kg

**Features:**

- ▶ Sold in pairs.
- ▶ Precisely ground and high accuracy of V groove.
- ▶ Suitable for processing steel rod or testing concentricity.
- ▶ Clamping range  $\varnothing 3 \sim \varnothing 20$
- ▶ Height deviation: 0.005mm
- ▶ Squareness: 0.005mm
- ▶ V groove acc. within 0.005mm

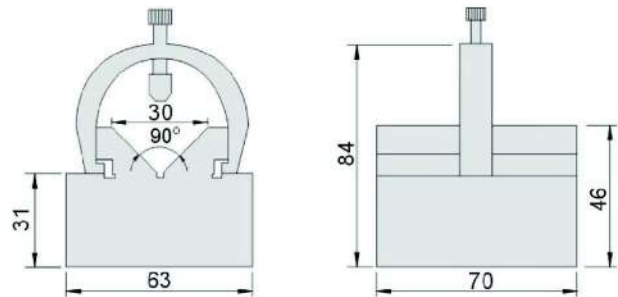
**55008**

PV150/200

**V Blocks with C Clamp****Features:**

- ▶ Suitable for machining, EDM, testing purposes.
- ▶ Clamping range:  $\varnothing 3.5\text{mm} \sim \varnothing 33\text{mm}$  (PV150),  
 $\varnothing 3.5\text{mm} \sim \varnothing 41\text{mm}$  (PV200)
- ▶ V groove parallelism 0.005mm / 100mm
- ▶ Squareness within 0.005mm / 100mm
- ▶ Material: SKS3 , HRC56°~ 60°
- ▶ Sold in pairs.

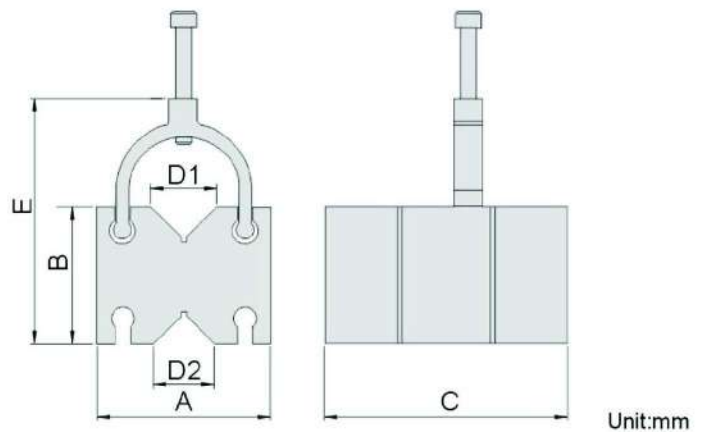

Unit:mm

Order No.	Model	A	B	C	D1	D2	E	N.W.
55008-01	PV150	64	45	70	29	24	90	1.3kg
55008-02	PV200	90	70	125	34	31	125.5	5.2kg



# Measuring Tool

**55010**

S100

Sine Bar



N.W. 0.8kg

## Features:

- ▶ Collocate with gauge blocks for measuring workpiece' angle.
- ▶ Parallelism within 0.003mm
- ▶ Biaxial accuracy  $\pm 0.003\text{mm}$
- ▶ Material: YK30 , HRC56<sup>o</sup>~ 60<sup>o</sup>

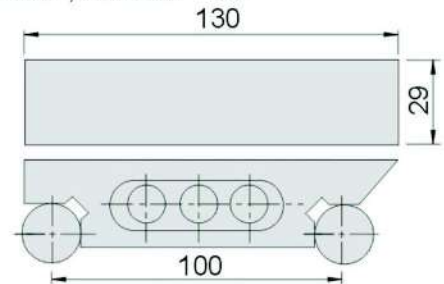

**55015**

SB

Magnetic Sine Bar



N.W. 0.3kg

## Features:

- ▶ Collocate with gauge blocks for measuring workpiece' angle.
- ▶ Parallelism within 0.003mm
- ▶ Squareness within 0.005mm
- ▶ Biaxial accuracy  $\pm 0.003\text{mm}$
- ▶ Material: YK30 , HRC56<sup>o</sup>~ 60<sup>o</sup>

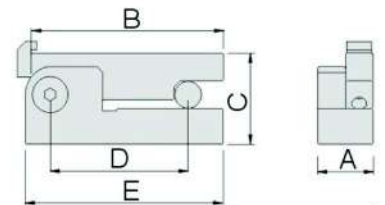
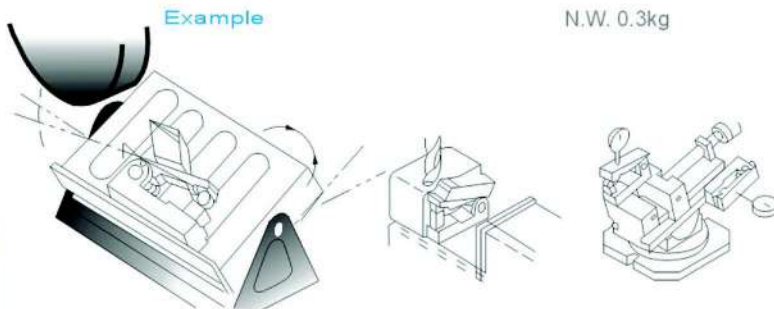

Unit:mm

Order No.	Model	A	B	C	D	E	N.W.
55015-01	SB50	20	70	33	50	72	0.3kg
55015-02	SB100	28	120	36	100	122	0.7kg

**55020**

MSB100

Magnetic Sine Bar



N.W. 2.0kg

## Features:

- ▶ Collocate with gauge blocks for measuring workpiece' angle.
- ▶ Angular deviation within 30 sec.
- ▶ Material: SKS , HRC56<sup>o</sup>~ 60<sup>o</sup>

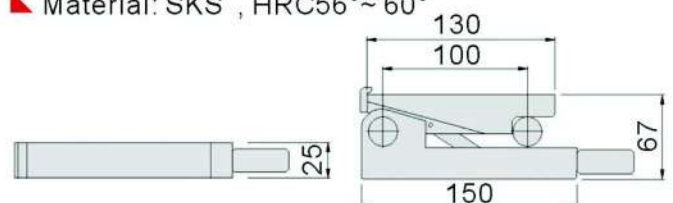

# Measuring Tool

## 55060 VC45 Precision Measure Holding Tool

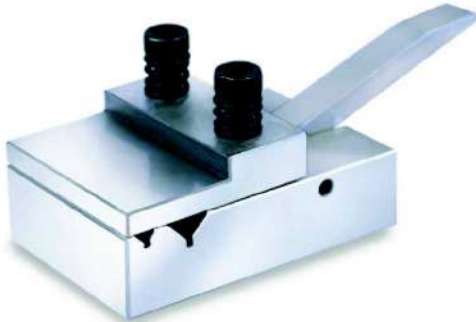

N.W. 0.46kg

### Features:

- ▶ Suitable for projector, microscope, loupe, CMM to clamp small workpiece.
- ▶ Clamping range: Max.  $\varnothing 12\text{mm}$

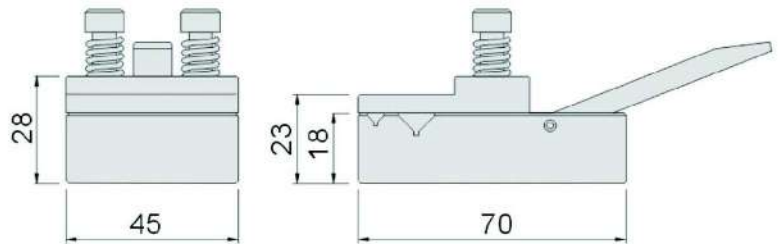

D05

## 55610 CHM-SE Precision Universal Thin Chuck Pedestal

CHM-SE02



CHM-SE03



### Features:

- ▶ Swivel base assembly with Thin 3-Jaw Chuck to achieve angle adjustments.
- ▶ Suitable for applying on 3D-Measuring to clamp round workpieces.
- ▶ For more info on Thin 3-Jaw Chuck, please refer to page H12.

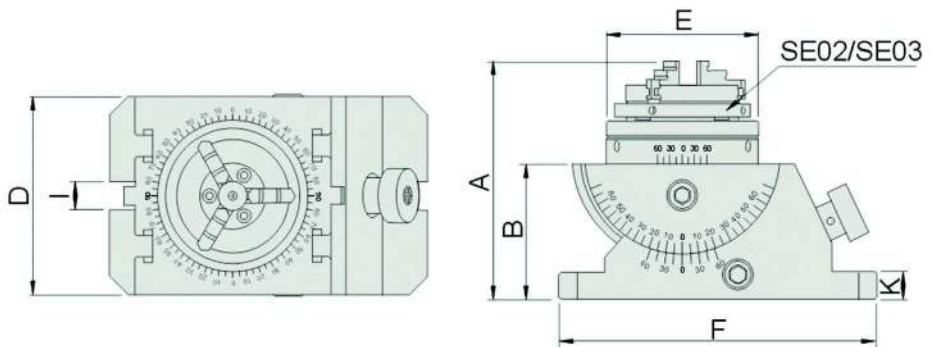

Unit:mm

Order No.	Model	A	B	D	E	F	I	K	N.W.
55610-01	CHM-SE02	132	75	110	$\varnothing 85$	178	16	15	11kg
55610-02	CHM-SE03	150	75	110	$\varnothing 112$	178	16	15	12kg

MEASURING TOOL

D38



Emmepi Utensileria s.r.l.

+39 0445 576210

Via Lago di Albano, 5 - 36015 Schio (VI)

ordini@utensileria.it

utensileria.it

**65006****CHM-ER40****Precision Universal ER Chuck****Features :**

- ▶ Swivel base assembly with ER40 Chuck to achieve angle adjustments.
- ▶ Suitable for applying on milling, grinding and engraving... etc
- ▶ For more info on ER40 collet chuck, please refer to page F85.

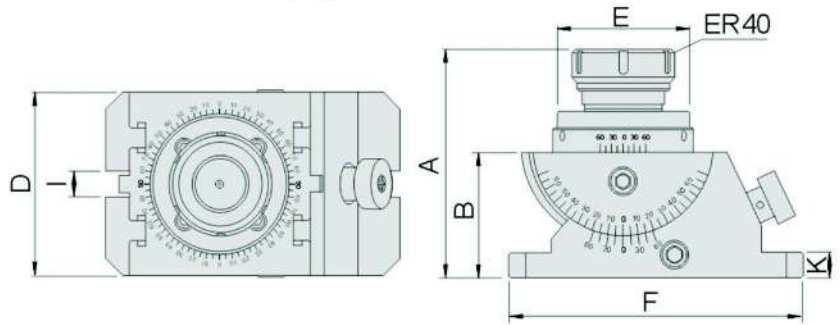

Unit:mm

Order No.	Model	A	B	D	E	F	I	K	N.W.
65006	CHM-ER40	137	75	110	∅80	178	16	15	11kg

**65008****CHM-SC****Precision Universal ER Chuck****CHM-SC03****Features :**

- ▶ Swivel base assembly with 3-Jaw Chuck to achieve angle adjustments.
- ▶ Suitable for applying on milling, grinding and engraving... etc
- ▶ For more info on 3-Jaw Chuck, please refer to page H01.

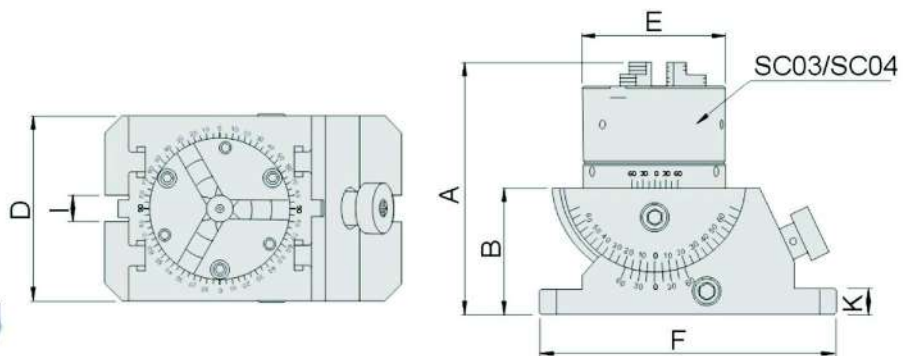
**CHM-SC04**

Unit:mm

Order No.	Model	A	B	D	E	F	I	K	N.W.
65008-01	CHM-SC03	150	75	110	∅85	178	16	15	12kg
65008-02	CHM-SC04	181	75	110	∅112	178	16	15	13kg

# Milling Machine Accessories

**65010-80**

**CHM80**

**Precision Universal Vice**

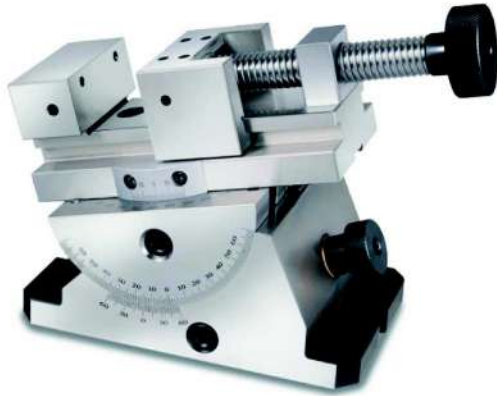

## Features:

- ▶ Precision graduation for accurate reading.
- ▶ Horizontal swivel through 360°.
- ▶ Tilting angle 45° vertically.
- ▶ Suitable for inclined surface, angular drilling machining on various machine tools.

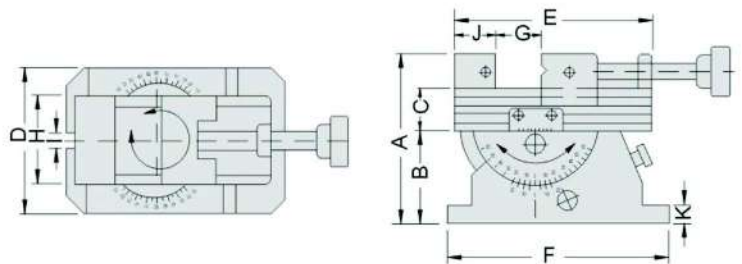

Unit:mm

Order No.	Model	A	B	C	D	E	F	G	H	I	J	K	N.W.
65010-80	CHM80	137	75	32	110	160	178	0~80	70	16	33	15	14kg

**65010-100**

**CHML50**

**Precision Three Dimension Vice**



## Features:

- ▶ Precision graduation for accurate reading.
- ▶ Horizontal swivel through 360°.
- ▶ Tilting angle 45° vertically.
- ▶ Suitable for inclined surface, angular drilling machining on various machine tools.
- ▶ With compound sine vise, it can be used for 3D machining.

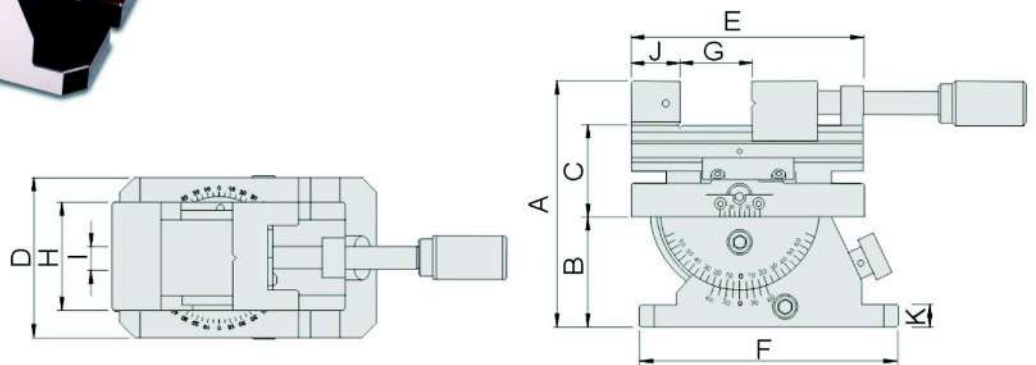

Unit:mm

Order No.	Model	A	B	C	D	E	F	G	H	I	J	K	N.W.
65010-100	CHML50	168	75	63	110	160	178	0~80	73	16	33	15	16kg

**65010-125****CHM125****Precision Universal Vice****Features:**

- ▶ Precision graduation for accurate reading.
- ▶ Horizontal swivel through 360°.
- ▶ Tilting angle 45° vertically.
- ▶ Suitable for inclined surface, angular drilling machining on various machine tools.

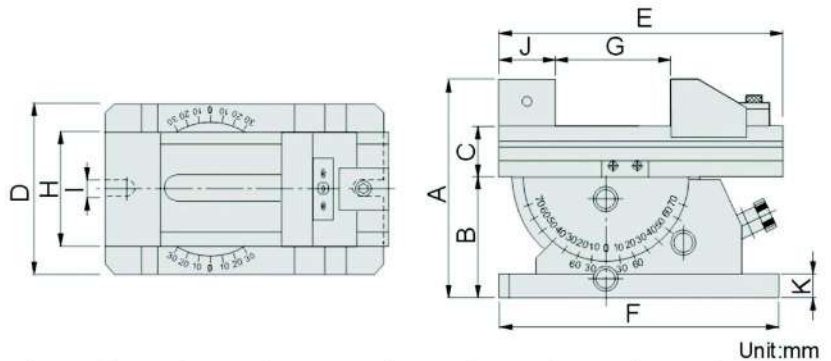

Unit:mm

Order No.	Model	A	B	C	D	E	F	G	H	I	J	K	N.W.
65010-125	CHM125	216	128	45	180	310	300	0~150	125	18	50	25	53kg

**65010-300****CHM-HT300****Precision Two Dimension Tables****Features:**

- ▶ Table with T-slot assembly with swivel base for rotation and angle adjustment.
- ▶ Suitable for inclined surface, angular drilling machining on various machine tools.

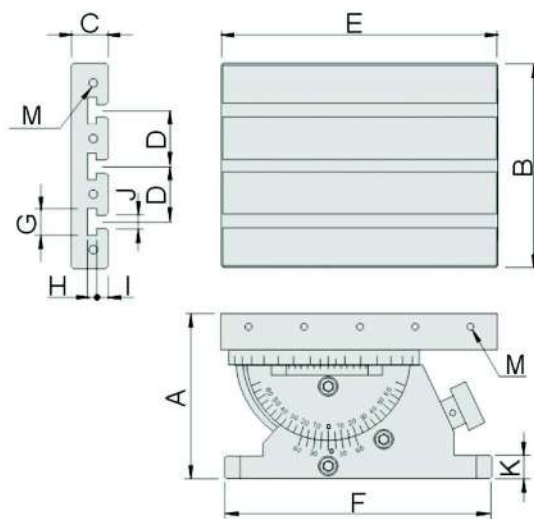

Unit:mm

Order No.	Model	A	B	C	D	E	F	G	H	I	J	K	M	Clamp	N.W.
65010-300	CHM-HT300	183	220	40	60	300	300	28	10	12	14	25	M8	M16	47kg



# Milling Machine Accessories

**65700**

**LA Right Angle Plates**



## Features:

- ▶ Precision ground and accurate angle.
- ▶ Material, YK30, HRC56°~58°
- ▶ Parallelism: 0.003mm/100mm
- ▶ Perpendicularity: 0.005mm/100mm

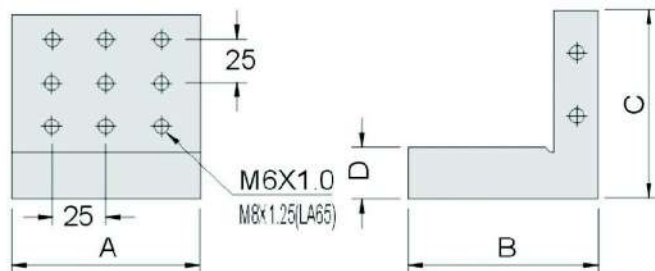

Unit:mm

Order No.	Model	A	B	C	D	N.W.
65700-34	LA34	73	73	100	25	2.5kg
65700-44	LA44	100	100	100	25	3.4kg
65700-46	LA46	100	100	150	25	4.3kg
65700-62	LA62	200	120	200	40	17.5kg
65700-65	LA65	300	150	300	50	45.5kg

**65710**

**LB Right Angle Plates**



## Features:

- ▶ Precision ground and accurate angle.
- ▶ Screw holes are made for fixing mold fixture.
- ▶ Material, Sk2, HRC56°~58°
- ▶ Parallelism: 0.003mm/100mm
- ▶ Perpendicularity: 0.005mm/100mm

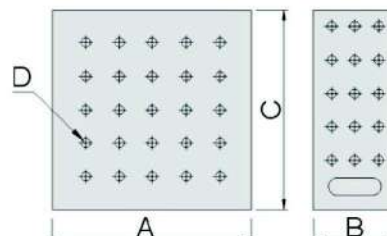

Unit:mm

Order No.	Model	A	B	C	D	N.W.
65710-150	LB150	150	63	150	M8XP1.25	10.5kg
65710-200	LB200	200	73	200		22.4kg
65710-250	LB250	250	83	250		39.7kg
65710-300	LB300	300	93	300		64.5kg

**65720**

GC10,12

**Angle Block Set****Features:**

- ▶ Suitable for inspection or calibrating angles.
- ▶ Light magnetized for better holding when measuring.
- ▶ Utilised as angle fixture on grinding machine.
- ▶ Accuracy:  $\pm 10''$
- ▶ Material, S50C, HRC52<sup>o</sup>~55<sup>o</sup>
- ▶ Size: 3" long and 1/4" thick

Order No.	Model	Specification	Qty/Set	N.W.
65720-10	GC10	1°, 2°, 3°, 4°, 5°, 10°, 15°, 20°, 25°, 30°	10	0.5kg
65720-12	GC12	1/4°, 1/2°, 1°, 2°, 3°, 4°, 5°, 10°, 15°, 20°, 25°, 30°	12	0.6kg

**65730**

GC20

**Universal Angle Block Set****Features:**

- ▶ Suitable for inspection or calibrating angles.
- ▶ Utilised as angle fixture on grinding machine.
- ▶ Accuracy:  $\pm 10''$
- ▶ Material, S50C, HRC52<sup>o</sup>~55<sup>o</sup>
- ▶ Size: 3" long and 1/4" thick

Order No.	Model	Specification	Qty/Set	N.W.
65730	GC20	1/2° 1° 2° 3° 4° 5° 10° 15° 30°	9	1.5kg

**65740**

ZT02-10

**Universal Angle Block Set****Features:**

- ▶ Suitable for inspection or calibrating angles.
- ▶ Utilised as angle fixture on grinding and milling machine.
- ▶ Accuracy:  $\pm 10''$
- ▶ Material, S50C, HRC52<sup>o</sup>~55<sup>o</sup>
- ▶ Size: 3" long and 1/4" thick

Order No.	Model	Specification	Qty/Set	N.W.
65740	ZT02-10	0° 1/4° 1/2° 1° 2° 3° 4° 5° 10° 15° 20° 25° 30° 35° 40° 45° 0°	17	1.5kg



# Milling Machine Accessories

**65750**

**P85**

**P85 Precision Parallels Set**



N.W. 5.5kg

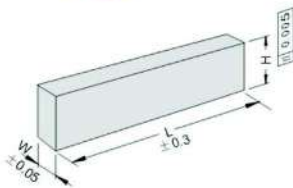

## Features:

- ▲ Accuracy:  $H \pm 0.01\text{mm}$
- ▲ Hardness: HRC48°~55°
- ▲ 18 pcs in a set.

Unit:mm

Order No.	WxHxLxPCS
P85	8.5x14x150x2
	8.5x16x150x2
	8.5x20x150x2
	8.5x24x150x2
	8.5x30x150x2
	8.5x32x150x2
	8.5x36x150x2
	8.5x40x150x2
8.5x44x150x2	

**65760**

**P100**

**P100 Precision Parallels Set**



N.W. 10.3kg

## Features:

- ▲ Accuracy:  $H \pm 0.01\text{mm}$
- ▲ Hardness: HRC48°~55°
- ▲ 18 pcs in a set.

Unit:mm

WxHxLxPCS
5x16x100x2
6x18x100x2
8x24x100x2
10x30x100x2
12x36x150x2
14x48x150x2
18x60x150x2
22x62x150x2

Unit:mm

Clamp Size
WxHxCxLxPCS
15x31x2.5x200x2

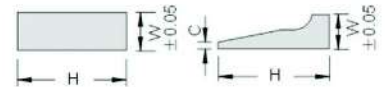

**65770**

**P150**

**P150 Precision Parallels Set**



N.W. 9.2kg

## Features:

- ▲ Accuracy:  $H \pm 0.01\text{mm}$
- ▲ Hardness: HRC48°~55°
- ▲ 28 pcs in a set.

Unit:mm

WxHxLxPCS
10x14x150x2
10x16x150x2
10x18x150x2
10x20x150x2
10x22x150x2
10x24x150x2
10x26x150x2

Unit:mm

WxHxLxPCS
10x28x150x2
10x30x150x2
10x32x150x2
10x35x150x2
10x40x150x2
10x45x150x2
10x50x150x2

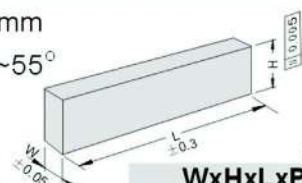

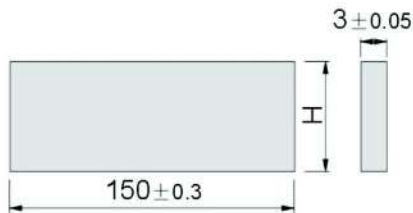
**65780****P60****Precision Parallels Set****Features:**

- ▶ Parallelism:  $H \pm 0.005\text{mm}$
- ▶ Hardness: HRC48°~55°
- ▶ Material: Alloy Tool Steel

Order No.	Model	Specification									
		$H \pm 0.01$									
<b>65780</b>	P60	13	16	19	22	25	28	31	35	38	41

Unit:mm

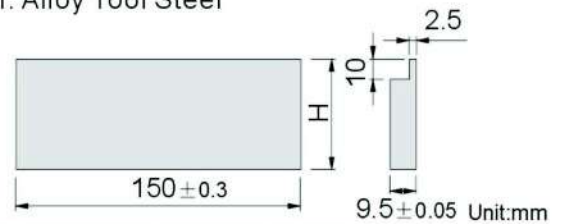
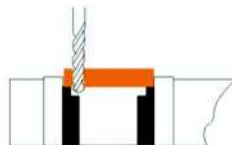
**65790****P70****Precision Parallels Set****Features:**

- ▶ Parallelism:  $H \pm 0.005\text{mm}$
- ▶ Hardness: HRC52°~58°
- ▶ Material: Alloy Tool Steel

Order No.	Model	Specification					
		$H \pm 0.01$					
65790	P70	25	30	35	40	45	48

Unit:mm

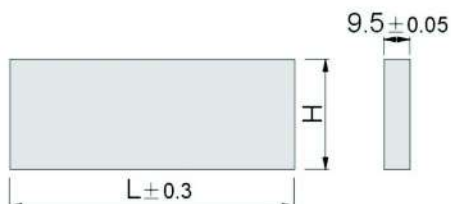
**65800****P80****Precision Parallels Set****Features:**

- ▶ Parallelism:  $H \pm 0.005\text{mm}$
- ▶ Hardness: HRC52°~58°
- ▶ Material: Alloy Tool Steel

Order No.	Model	Specification						
		$H \pm 0.01$						
<b>65800-01</b>	P80-1	25	30	35	40	45	48	150
<b>65800-02</b>	P80-2	35	40	45	50	55	58	200

Unit:mm

**65830**

T

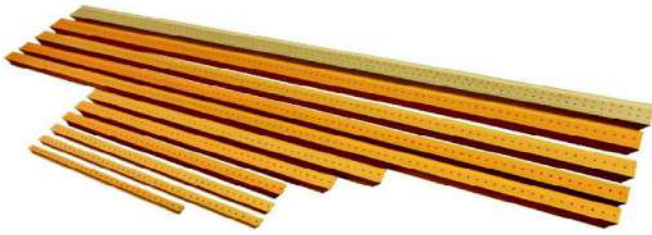
**Milling Table Slot Cover****Features:**

- ▶ Effective item for saving cleaning time.

Unit:mm

Order No.	Model	Length	Width	Pcs	N.W.
65830-01	T-10	300	10	6	0.25kg
65830-02	T-12	400	12	6	0.50kg
65830-03	T-14	400	14	6	0.68kg
65830-04	T-16	400	16	6	0.90kg
65830-05	T-18	450	18	6	1.28kg
65830-06	T-20	1000	20	5	3.50kg
65830-07	T-22	1000	22	5	4.30kg
65830-08	T-24	1000	24	5	5.10kg
65830-09	T-28	1000	28	5	6.90kg
65830-10	T-36	1000	36	5	11.50kg

**Application Examples:**

# Lathe Machine Accessories

**66800**

SC

**3-JAWS Regular Type Chuck**

## Features:

- ▶ Suitable for clamping small round workpiece.
- ▶ Auto centering.
- ▶ Internal Jaw & External Jaw are interchangeable.

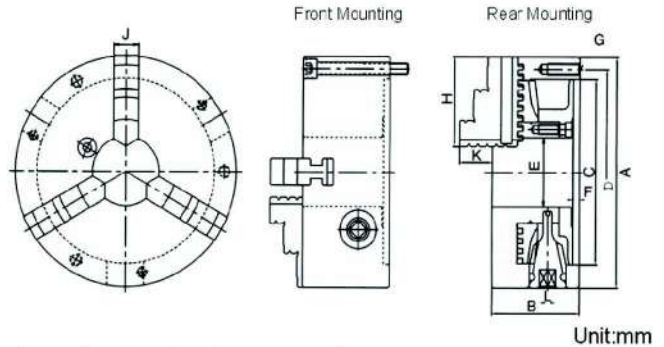

Unit:mm

Order No.	Model	A	B	C	D	E	F	G	H	J	K	L	Max.Speed (r.p.m.)	Max.Gripping Diameter		N.W.
														O.D.Clamping	I.D.Clamping	
66800-03	SC03	85	45	60	73	16	3.5	3-M6x1P	35	11	15	7	2500	∅2-70	∅24-64	1.5kg
66800-04	SC04	112	58	80	95	24	4.5	3-M8x1.25P	42	14	17	8	2500	∅3-90	∅32-84	3.3kg

Specify: "Front mounting" or "Rear mounting" when ordering.

H01

**66915**

SE

**Thin Chuck**

## Features:

- ▶ Compact design, light, thin, short concept is suitable for measuring work.
- ▶ Rotate the chuck knob directly for gripping and loosening, no need wrench.
- ▶ Chuck body is made of steel to enhance safety operations for high speed machining.
- ▶ Jaws can be reversibly installed.
- ▶ 2" chuck can even clamp up to the smallest size of 0.8mm.

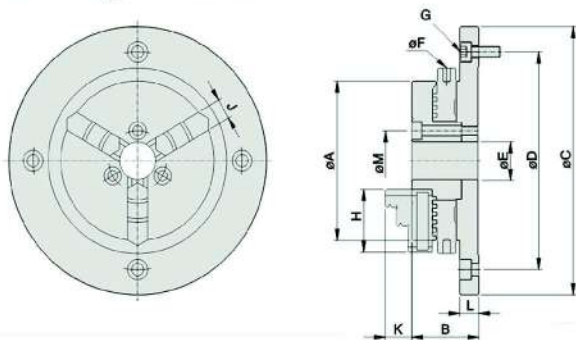

Unit:mm

Order No.	Model	A	B	C	D	E	F	G	H
66915-02	SE02	63	28	118	100	16	4	4-M5x0.8P	27
66915-03	SE03	85	37	143	116	20	4	4-M6x1P	35

Order No.	Model	J	K	L	M	Max.Gripping Diameter		N.W.
						O.D.Clamping	I.D.Clamping	
66915-02	SE02	8	13	8	26	∅0.8~∅63	∅23~∅58	1.2kg
66915-03	SE03	11	15	10.5	32	∅1~∅81	∅31~∅70	2.9kg

H12



Emmepi Utensileria s.r.l.

+39 0445 576210

Via Lago di Albano, 5 - 36015 Schio (VI)

ordini@utensileria.it

utensileria.it

LATHE MACHINE ACCESSORIES



**SINERGYA È ORA PARTE DI EMMEPI UTENSILERIA.**



**SCOPRI LA GAMMA  
COMPLETA  
E AGGIORNATA**

[utensileria.it/sinergya/](https://utensileria.it/sinergya/)



**Emmepi Utensileria s.r.l.**  
SEDE LEGALE  
+39 0445 576210  
Via Lago di Albano, 5 - 36015 Schio (VI)



**Cuma**  
DIVISIONE PRODUZIONE  
+39 049 870 0810  
Viale della Regione Veneto, 22, 35127 Padova (PD)

[utensileria.it](https://utensileria.it)  
[ordini@utensileria.it](mailto:ordini@utensileria.it)