



# ACCESSORI E STRUMENTI DI MISURA SINERGYA



**Emmepi Utensileria s.r.l.**  
SEDE LEGALE  
+39 0445 576210  
Via Lago di Albano, 5 - 36015 Schio (VI)



**Cuma**  
DIVISIONE PRODUZIONE  
+39 049 870 0810  
Viale della Regione Veneto, 22, 35127 Padova (PD)

[utensileria.it](http://utensileria.it)  
[ordini@utensileria.it](mailto:ordini@utensileria.it)

# SINERGYA

## Accessori e Strumenti di Misura *Accessories and Measuring Tools*



SM/04-2026



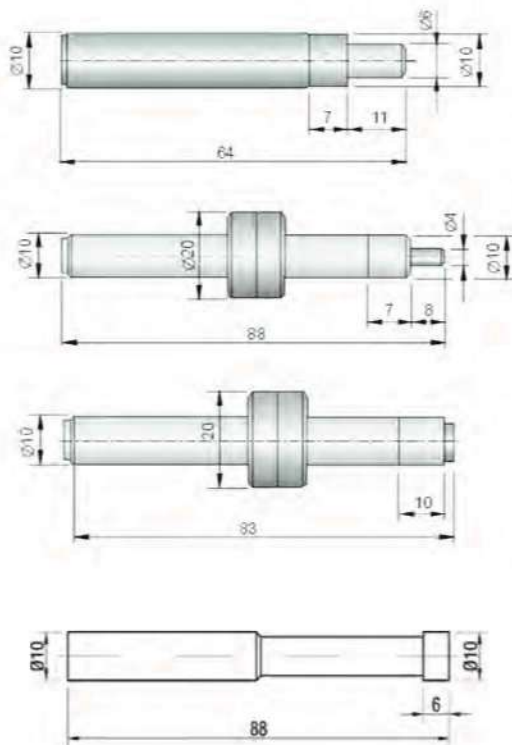

**Caratteristiche / Features:**

- Inserire il centratore direttamente sul mandrino portautensile.
- Premere sulla parte inferiore del centratore portandola in posizione leggermente eccentrica.
- Ruotare ad una velocità massima di 400 ~ 600 rpm.
- Avvicinare con prudenza l'apparecchio centratore al pezzo da lavorare. Non appena la testa di contatto scorre liscia per alcuni millimetri lungo la superficie del pezzo l'operazione di misura è da considerarsi terminata.
- La distanza asse mandrino/superficie del pezzo è ora la metà del diametro della testa di misura.
  
- *Straight shank can be install directly on milling chuck or drilling chuck.*
- *Slightly press on the edge of sensor unit to make it eccentric .*
- *Rotate with speed of 400 - 600 rpm.*
- *Make sensor unit contact to the end face of workpiece as shown Fig,2, then move steadily until turning into Fig.3 looks keep still. When making fine-moving and it looks as Fig.4, and this coordinate position is the basis point.*
- *The position of end face of the workpiece is the coordinate position of sensor unit plus radius 5 mm.*

**Avvertenze / Cautions:**

1. Non piegare e/o tirare il prodotto con forza.
2. Mantenere sempre pulite le superfici di contatto.
3. Non applicare mai oltre 600 giri.
4. Non utilizzare su superfici orizzontali.
  
1. Do not bend the product or pull with force.
2. Always keep clean for the slide face.
3. Never apply over 600 rpm.
4. Never apply it on horizontal machinery.

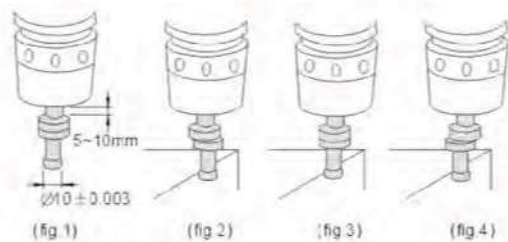

**Centratori Meccanici**  
*Mechanical Edge Finder*

Model	LxWxH*	N.W.
SME-610	94x24x24	0.08kgs
SME-410	94x24x24	0.04kgs
SME-1020	94x24x24	0.14kgs
SME-TN10	94x24x24	0.05kgs
SME-TN410	94x24x24	0.14kgs
SME-410ST	94x24x24	0.12kgs
SME-1020ST	94x24x24	0.14kgs

\* Confezione (misure indicative)    TN - Non Magnetico    ST - Acciaio Inox  
 \* Packaging (indicative dimensions)    TN - Not Magnetic    ST - Stainless Steel

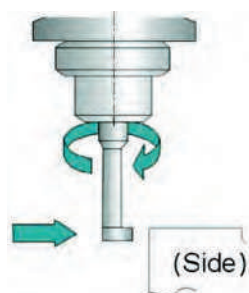
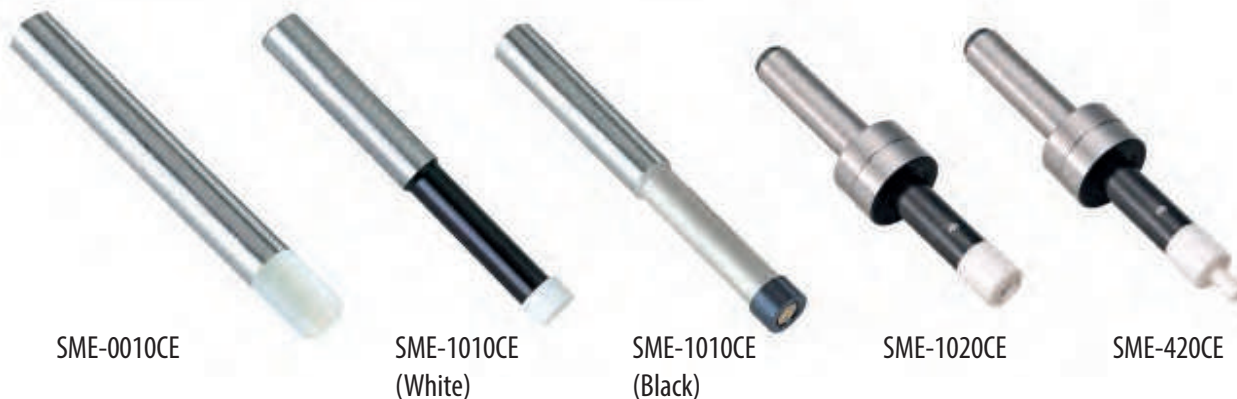

1. Ruotare avvicinandosi lentamente all'oggetto.

1. Rotate back, and approaching object slowly.

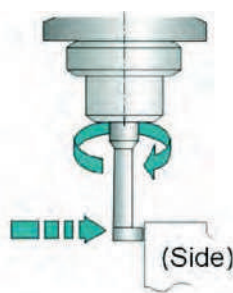

2. A contatto avvenuto interrompere il movimento e tornare leggermente indietro.

2. Stop moving when contact and vibrates, and move it back.

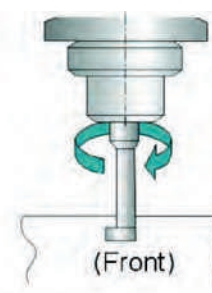

3. Mantenere una distanza tra cilindro e superficie pari al raggio di rotazione di 5mm.

3. It would be consistent between cylinder and workpiece's face when reaching 5mm in radius.

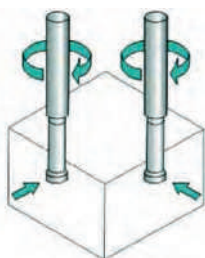

Impostare le posizioni standard.

Set up the standard positions.

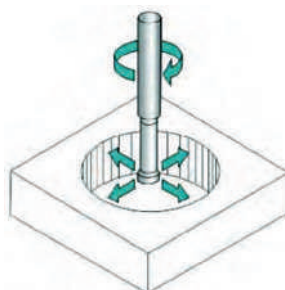

Misurazione del diametro interno.

Measuring the internal diameter.

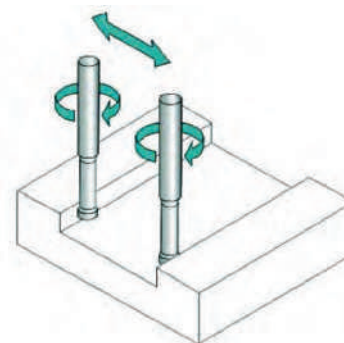

Misurazione fessure e scanalature.

Slot and groove measurement.

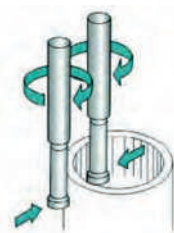
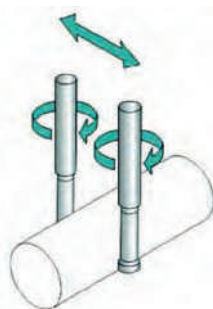

### Centratori Meccanici Ceramici non Magnetici Non-Magnetic Ceramic Mechanical Edge Finder

Model	LxWxH*	N.W.
SME-0010CE	118x42x25	0.1kgs
SME-1010CE**	118x42x25	0.1kgs
SME-1020CE	118x42x25	0.1kgs
SME-420CE	118x42x25	0.1kgs

\* Confezione (misure indicative)  
\* Packaging (indicative dimensions)

\*\* Disponibile con sensore in ceramica Bianca o Nera.  
\*\* Available in the version with white or black ceramic sensor.



## Caratteristiche / Features:

- Materiale: lega acciaio Cr-Mo per utensili.
- Durezza: HRC 55' +/- 1'
- R.P.M.: Entro 600 ÷ 1000
- Precisione entro 0.003mm
- Utilizzabile su fresatrici, trapani e macchine per alesatura.

- *Material: Cr-Mo alloy tool steel.*
- *Hardness: HRC 58' +/- 1'.*
- *R.P.M.: Within 600 ÷ 1000*
- *Accuracy within 0.003mm*
- *Suitable for milling machine, drill machine and boring machine.*

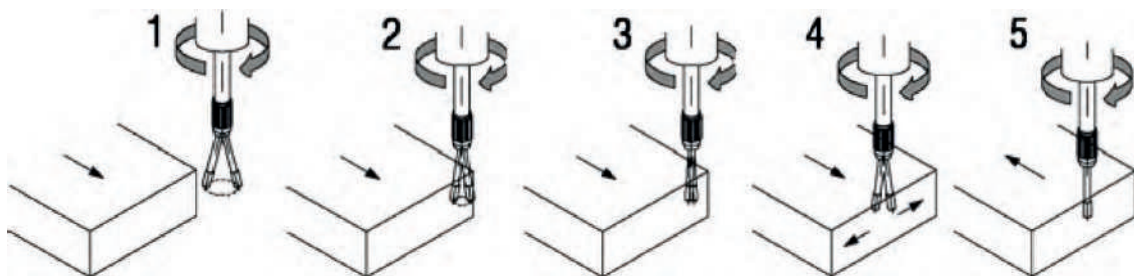
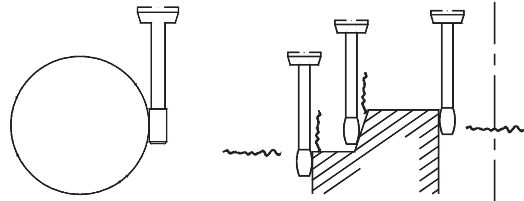
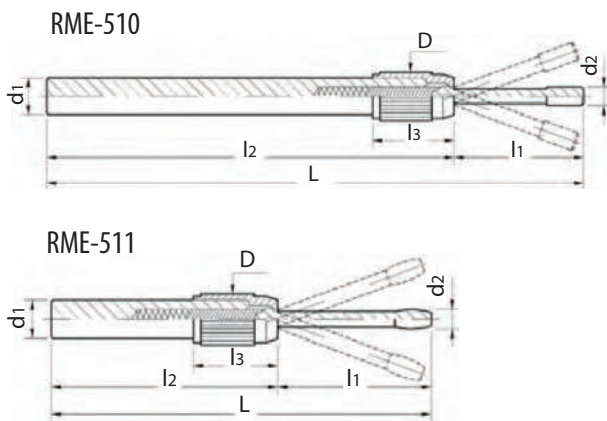

### Centratori Rotanti in Acciaio Steel Rolling Edge Finder

Model	N.W.	L	l1	l2	l3	D	d1	d2
RME 510*	0.75kgs	145	35	110	22	13	10	5
RME 511	0.44kgs	99	40	59	22	13	10	5

\* Prodotto disponibile fino ad esaurimento scorte.  
\* Product available while stocks last.

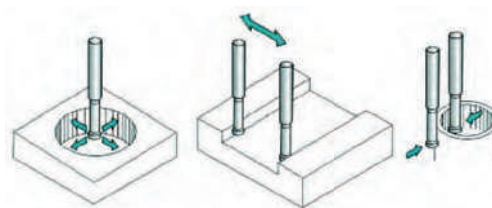
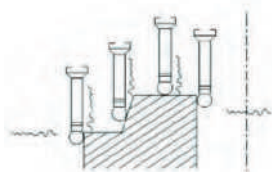
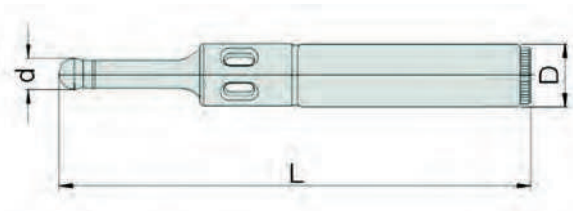
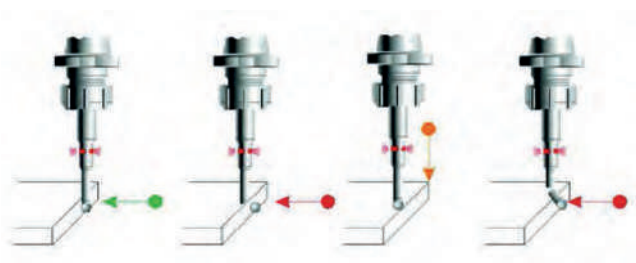
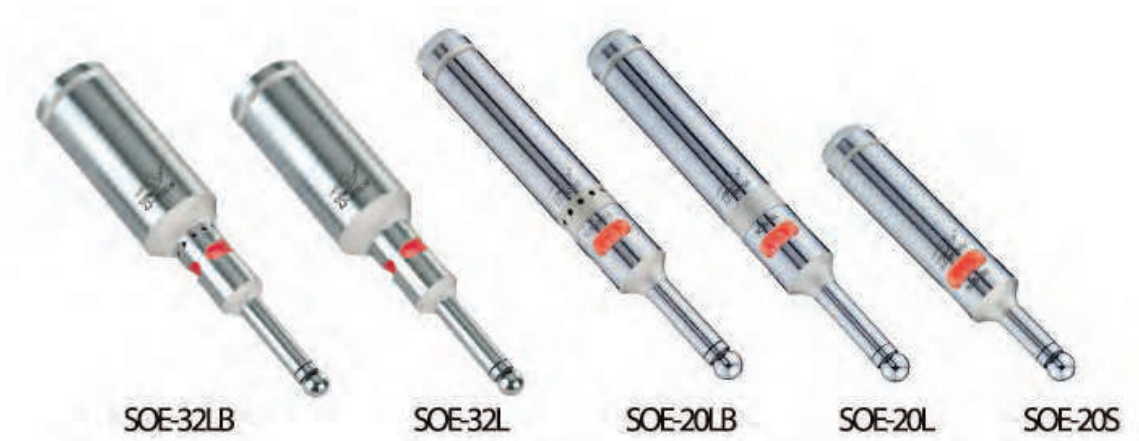

## Caratteristiche / Features:

- Non necessita di rotazioni durante la misurazione.
- Elevata efficienza nel trovare posizioni e margini di lavoro.
- Sensore con molla di sicurezza.
- Precisione 0,005 mm.
- Tipo di batteria:
  - Um5 #, 1.5 v x 2 pz (SOE 20L, 32L)
  - Um5 #, 23A x 12V x 1pc (SOE 20S, 20LB, 32LB)
- *No rotation needed while measuring.*
- *Increase efficiency to find positions and work edges.*
- *Safety spring puller which holds the ball back to the position when ball breaks from ball seat.*
- *Accuracy 0.005mm.*
- *Battery type:*
  - Um5#, 1.5v x 2pcs (SOE 20L, 32L)
  - Um5#, 23A x 12V x 1pc (SOE 20S, 20LB, 32LB)

### Tastatori Elettro-Ottici Optical Edge Finder

Model	D	L	d	Feature	LxWxH*	N.W.
SOE-20S	ø20	120	ø10	Lighting	200x72x45	0.30kgs
SOE-20L				Lighting		0.36kgs
SOE-20LB	ø32	158	ø10	Lighting/Sound		0.36kgs
SOE- 32L				Lighting		0.64kgs
SOE 32LB				Lighting/Sound		0.64kgs

\* Confezione (misure indicative)  
\* Package (indicative dimensions)



### Caratteristiche / Features:

- Altezza di regolazione:  $50 \pm 0,005$  mm.
  - Base magnetica per una facile installazione.
  - La spia rossa si accende al contatto.
  - Bloccaggio calibratura e regolazione altezza.
  - Uso verticale ed orizzontale.
  - Tipo di batteria: dotazione LR44 / A76 / G13 x 2pz.
- 
- *Setting height:  $50 \pm 0.005$ mm.*
  - *Magnetic base for easy setup.*
  - *Red lamp will be lit up when touched.*
  - *Height can be fine-tuning and calibrated by gauge blocks.*
  - *Can be used vertically and horizontally.*
  - *Battery type: LR44 / A76 / G13 x 2 purchase.*

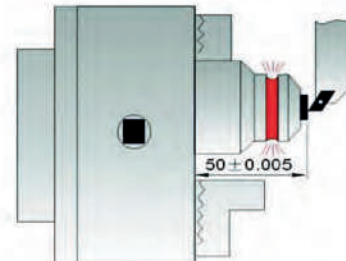
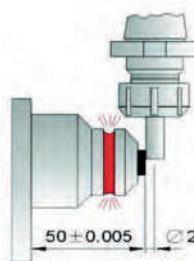
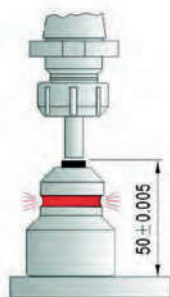

### Caratteristiche / Features:

- Impostazione della lunghezza dell'utensile sulle macchine di fresatura e tornitura CNC.
  - Altezza di regolazione:  $50 \pm 0,005$  mm.
  - Grande superficie di misurazione e funzionamento semplice.
  - Bassa forza elastica per evitare la rottura delle frese e degli utensili di piccole dimensioni.
  - Calibrazione facile con basi parallele o manometriche.
  - Migliore parallelismo, sensibilità e precisione.
- 
- *Setting tool length on CNC milling and lathe machines.*
  - *Setting height:  $50 \pm 0.005$ mm.*
  - *Large measuring surface and easily operated.*
  - *Low spring force to avoid breakage of small end mill or drill.*
  - *Easily calibrated by ground parallel or gauge blocks.*
  - *ZiP-50A with better parallel, sensibility and accuracy.*

## Caratteristiche / Features:

- Impostazione della lunghezza dell'utensile sulla fresatura CNC e sul tornio.
  - Altezza di regolazione: 50 +/- 0,005 mm.
  - Grande superficie di misurazione e funzionamento semplice.
  - Bassa forza elastica per evitare la rottura delle frese e degli utensili di piccole dimensioni.
  - Calibrazione facile con basi parallele o manometriche.
- 
- *Setting tool length on CNC milling and the lathe machine.*
  - *Setting height: 50 +/- 0.005 mm.*
  - *Large measuring surface and easily operated.*
  - *Low spring force to avoid breakage of small end mill or drill.*
  - *Easily calibrated by ground parallel or gauge blocs.*

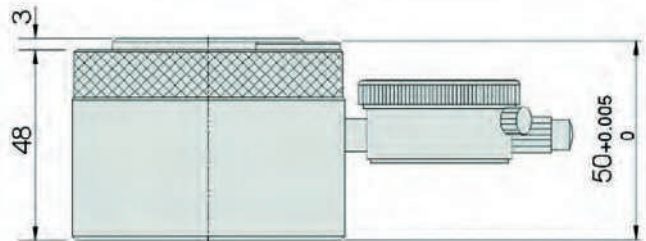
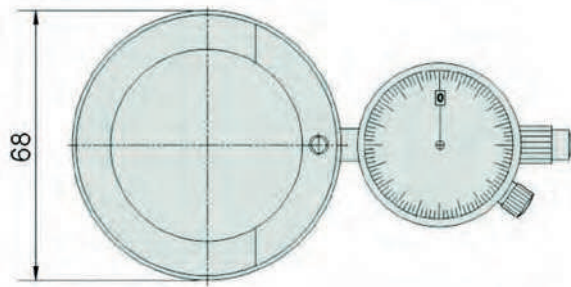

## Istruzioni / Instruction:

Per calibrare l'azzeratore posizionare un parallelo sullo strumento, premere contro la superficie del piattello fino a fine corsa e, contemporaneamente, impostare il comparatore sullo "0".

*Calibrate the Zero Setter by putting a parallel on the setter and press it against on the pre ground surface and set the dial gauge at "0".*

## Misurazione / Measurement:

Installare l'azzeratore sulla macchina o sulla superficie del pezzo, spostare il mandrino per fare in modo che lo strumento di taglio tocchi la superficie di misurazione e leggere con attenzione il comparatore. Quando il comparatore indica "0", la distanza tra la superficie della macchina e l'utensile è di 50 mm.

*Set up the setter on machine or workpiece's surface, move spindle to make cutting tool contact the measuring surface and read the dial gauge with care. When the dial gauge points at "0", the distance between tool machine table is 50 mm.*

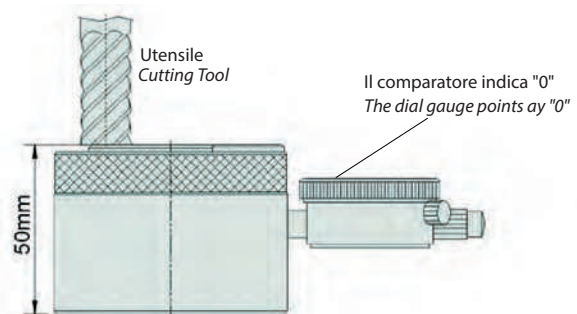
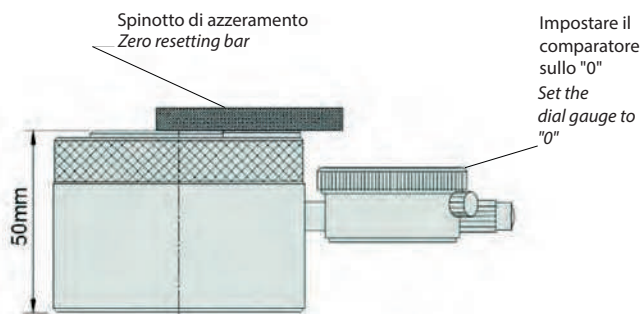

### Azzeratori Setter and Presetter

Model	Height	G.W.	LxWxH	Magnetism
ZOV 50*	50 +/- 0.005	1.25	50x68x68	Bottom no magnetic
ZOP 50*	50 +/- 0.005	0.60	50x53x53	Bottom have magnetic
ZIP 50A	50 +/- 0.005	1.30	50x63x63	Bottom have magnetic

\* Spinotto di azzeramento non compreso nel kit standard.

\* Zero resetting bar not included in the standard kit.

# MSB150

# Penna Magnetica



# LMB650

# Penna Magnetica LED



## Caratteristiche / Features:

- Indispensabile per raccogliere parti metalliche in spazi difficilmente raggiungibili.
- Puntale con torcia a LED (LMB650).
- Asciugare bene dopo contatto con superfici bagnate.
- *Easily pick up the fallen parts in hand unreachable places.*
- *With LED combined design, do not stare straight at the light (LMB650).*
- *Clean any water if contacted.*

### **Penne Magnetiche** *Magnetic Pen*

Model	Dimension	N.W.	Battery	Light	Holding Capacity
MSB150	Min.135/Max.650	0.40	No	No	Max. 1.8kg
LMB650	Min.160/Max.590	0.50	3Pcs./#LR41	LED	





**SINERGYA È ORA PARTE DI EMMEPI UTENSILERIA.**



**SCOPRI LA GAMMA  
COMPLETA  
E AGGIORNATA**

[utensileria.it/sinergy/](https://utensileria.it/sinergy/)



**Emmepi Utensileria s.r.l.**  
SEDE LEGALE  
+39 0445 576210  
Via Lago di Albano, 5 - 36015 Schio (VI)



**Cuma**  
DIVISIONE PRODUZIONE  
+39 049 870 0810  
Viale della Regione Veneto, 22, 35127 Padova (PD)

[utensileria.it](https://utensileria.it)  
[ordini@utensileria.it](mailto:ordini@utensileria.it)