



# PROGRAMMA JOLLY-NIK



**Emmepi Utensileria s.r.l.**  
SEDE LEGALE  
+39 0445 576210  
Via Lago di Albano, 5 - 36015 Schio (VI)



**Cuma**  
DIVISIONE PRODUZIONE  
+39 049 870 0810  
Viale della Regione Veneto, 22, 35127 Padova (PD)

[utensileria.it](http://utensileria.it)  
[ordini@utensileria.it](mailto:ordini@utensileria.it)

# JOLLY



2026/03

jolly-001

## JOLLY B MINI-TOOL JOLLY Z MINI-MILL

MULTIFUNZIONALE  
FACILE IMPIEGO  
ALTA EFFICIENZA  
BASSO COSTO

Z4:  
 $Ra \leq 0,4 \mu m$



## UN UTENSILE... MOLTEPLICI LAVORAZIONI!

Ampia scelta di **STELI** in funzione del tipo di lavorazione ed attacco. Sono realizzati in acciaio speciale al cromo, molibdeno e vanadio (**THG 2000**), ad alta resistenza meccanica, eseguiti in **h5**, adatti per **calettamento a caldo**.

Ampia scelta di **INSERTI** in funzione del tipo di lavorazione e del materiale da lavorare. Sono realizzati con qualità in **grana ultrafine K20** ed affilati con precisione in **classe E**.

Due differenti tipologie di **rivestimenti ad alto rendimento**:

- **DEVIL** (D1) per acciai legati e inox legati, acciai al carbonio e ghise meehanite;
- **ZIRCONIO** (ZRN) per acciaio inox, alluminio e leghe non ferrose.

A richiesta si realizzano inserti per profili speciali e rivestimenti dedicati a materiali difficili.



## JOLLY B MINI-TOOL

UTENSILI BILANCIATI A SINGOLO TAGLIENTE PER CENTRARE, SVASARE, TORNIRE, SFACCIARE, INCIDERE, SCANALARE, SMUSSARE E RAGGIARE SU CENTRI DI LAVORO, TORNI E PANTOGRAFI A CN.

**JOLLY B** è un utensile **Bilanciato** innovativo e **multifunzionale** per centri di lavoro, torni e pantografi a CN.

Può montare sullo stesso gambo diverse **geometrie di inserti**, per lavorazioni singole, per **centrare, svasare, tornire, sfacciare, incidere, scanalare, smussare e raggiare**.

Con i **JOLLY B** si possono eseguire **infinite lavorazioni combinate** con un solo piazzamento sia sui mandrini in rotazione sia sulle stazioni statiche dei torni.



## JOLLY Z MINI-MILL

MINI-FRESE A SINGOLO O A QUATTRO TAGLIENTI PER FINIRE, FRESARE, SMUSSARE E RAGGIARE ANCHE SOTTOSQUADRA.

**JOLLY Z** è una serie di **Mini-Frese** dal **design compatto**, a **1** o a **4** taglienti su diametro di taglio minimo!!!

Ideali per lavorazioni di **finitura** con  $Ra \leq 0,4 \mu m$  (con steli Z4), **fresatura, smussatura e raggiatura** anche **sottosquadra**.

**Altissime prestazioni tecnologiche: velocità** di avanzamento fino al **400% in più** grazie alla **rigidità** del corpo fresa ed alla **qualità** degli inserti.

SP0606-S

SP1010-S

SP1614-S

SP2017-120D-S

SP1010-L

SP1614-L

SP2018-142D-S

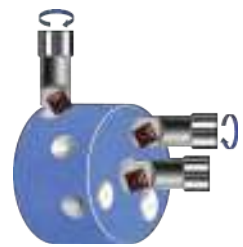
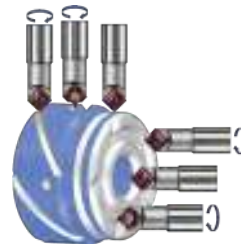
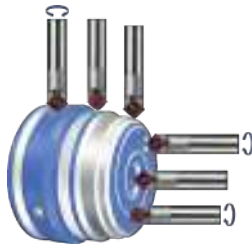
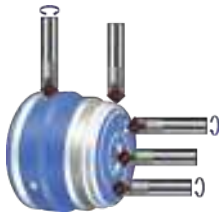
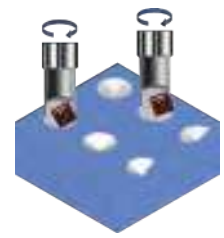
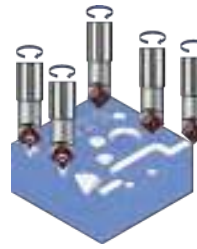
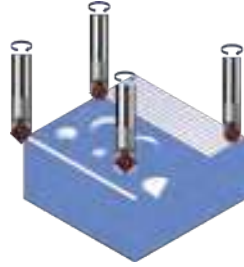
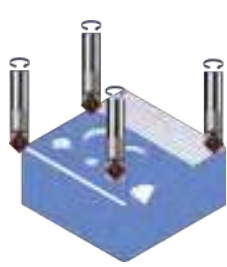

I DATI INDICATI NON SONO IMPEGNATIVI E POSSONO ESSERE MODIFICATI ANCHE SENZA PREAVVISO.

SCELTA DELL'INSERTO E SUE APPLICAZIONI

MODELLO STELO	TIPO DI LAVORAZIONE						ANGOLO				MATERIALE DA LAVORARE	RIVESTIMENTO		
	CENTRARE	SVASARE	TORNIRE	SFACCIARE	INCIDERE	SCANALARE	SMUSSARE	RAGGIARE	60°	90°			120°	142°
													ACCIAI LEGATI e INOX LEGATI ACCIAI AL CARBONIO GHISE MEEHANITE	DEVIL
													ACCIAIO INOX ALLUMINIO LEGHE NON FERROSE	ZRN
													MODELLO/TIPOLOGIA INSERTO	-D1 (DEVIL) +... = -ZRN
SP0606-S	●	●	●	●	●	●	●	●	●	●	●	●	SD050202CT-...	
SP1010-S	●	●	●	●	●	●	●	●	●	●	●	●	SD08020.CT-...	
SP1010-L	●	●	●	●	●	●	●	●	●	●	●	●	SD080201W60-...	
													SD080201W90-...	
SP1614-S	●	●	●	●	●	●	●	●	●	●	●	●	SD11T30.CT-...	
													SD11T30.CTP60-...	
													SD11T30.CTD20-... SD11T30.CTD25-... SD11T30.CTD315-...	(1) Fori da Centro (Simile DIN332 Forma R)
SP1614-L	●	●	●	●	●	●	●	●	●	●	●	●	SD11T308CTR10-... SD11T308CTR15-... SD11T308CTR20-... SD11T308CTR25-... SD11T308CTR30-...	
SP2017-120D-S	●	●	●	●	●	●	●	●	●	●	●	●	SD11T30.CT-...	
SP2018-142D-S	●	●	●	●	●	●	●	●	●	●	●	●		

(1) Lavorazioni ideali; (2)(3) Lavorazioni secondarie

**JOLLY B** Ø6MAX 30.000min<sup>-1</sup>

• SP0606-S

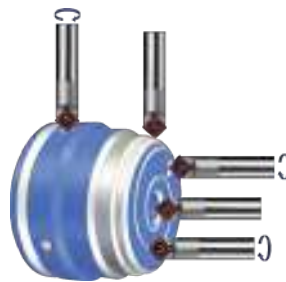
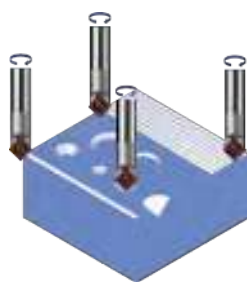

BILANCIATURA



Utensile multifunzionale bilanciato a singolo tagliente per centrare, svasare, tornire, sfacciare, incidere, scanalare e smussare.

Ogni stelo viene fornito di:

1 Vite; 1 Chiave Torx.

In **Optional**:

inserti per varie tipologie di lavorazioni e materiali.

**KIT Disponibili!** (Stelo + Inserti)

• SP0606-S

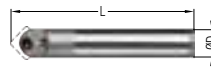

COD.	ØD [mm]	L [mm]	Vite (Inclusa)	Chiave (Inclusa)	Tipologia Inserti (Optional)
------	---------	--------	----------------	------------------	------------------------------

**JOLLY B**

STELI



SP0606-S

Ø6

40

SC20048

TORX-T6

SD050202CT-...

RICAMBI

SC20048

Vite Torx M2,0x4,8 - 0,8Nm

TORX-T6

Chiave Torx T6

COD.	Rivestimento Inserto	Q [mm]	S [mm]	Re [mm]	H [mm]	Minimo Ordine
------	----------------------	--------	--------	---------	--------	---------------

**INSERTI**

SD050203CT-...

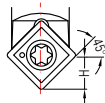
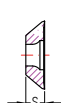
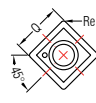
>> **MULTIFUNZIONE per:** Centrare, Svasare, Tornire, Sfacciare, Incidere, Scanalare e Smussare

SD050202CT-D1

DEVIL  
(HV 3800 ±200)

5,3

2

0,2

3,25

10 pz.

SD050202CT-ZRN

ZRN  
(HV 2500 ±300)

0,2

3,25

10 pz.

RIVESTIMENTO INSERTI: DEVIL

**KIT**

RIVESTIMENTO INSERTI: ZRN

COD.
KS00 S CT D1



STELO

1x SP0606-S

INSERTI

6x SD050202CT-D1

VITI e CHIAVE

2x SC20048  
1x TORX-T6

COD.
KS00 S CT ZRN



STELO

1x SP0606-S

INSERTI

6x SD050202CT-ZRN

VITI e CHIAVE

2x SC20048  
1x TORX-T6

# JOLLY B Ø10

MAX 20.000min<sup>-1</sup>

- SP1010-S
- SP1010-L

Utensili multifunzionali bilanciati a singolo tagliente per centrare, svasare, tornire, sfacciare, incidere, scanalare e smussare.

Ogni stelo viene fornito di:  
1 Vite; 1 Chiave Torx.

In **Optional**:  
inserti per varie tipologie di lavorazioni e materiali.

**KIT Disponibili!** (Stelo + Inserti)

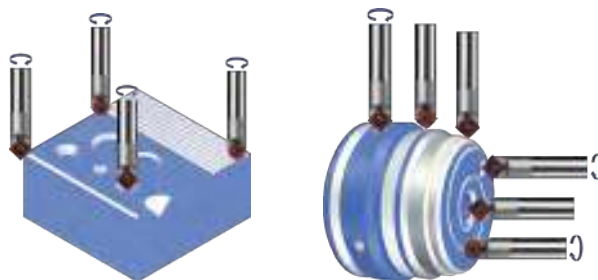

BILANCIATURA



- SP1010-S
- SP1010-L

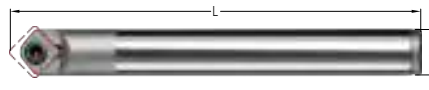

I DATI INDICATI NON SONO IMPEGNATIVI E POSSONO ESSERE MODIFICATI ANCHE SENZA PREAVVISO.

COD.	ØD [mm]	L [mm]	Vite (Inclusa)	Chiave (Inclusa)	Tipologia Inserti (Optional)
------	---------	--------	----------------	------------------	------------------------------

## JOLLY B



STELI		ØD [mm]	L [mm]	Vite (Inclusa)	Chiave (Inclusa)	Tipologia Inserti (Optional)
SP1010-S		Ø10	90	SC30055	TORX-T8	SD08020.CT... SD080201W...-....
SP1010-L			150			
RICAMBI						
SC30055	Vite Torx M3,0 H4x5,5 - 2,0Nm					
TORX-T8	Chiave Torx T8					

COD.	Rivestimento Inserto	Q [mm]	S [mm]	Re [mm]	H [mm]	Minimo Ordine
------	----------------------	--------	--------	---------	--------	---------------

## INSERTI

SD08020.CT... >> **MULTIFUNZIONE per:** Centrare, Svasare, Tornire, Sfacciare, Incidere, Scanalare e Smussare

	<b>SD080208CT-D1</b>	DEVIL (HV 3800 ±200)	8,3	2,38	0,8	4,9	10 pz.
	<b>SD080204CT-ZRN</b>	ZRN (HV 2500 ±300)			0,4	5,3	10 pz.

SD080201W60... >> **IDEALE per:** Incidere e Scanalare a 60°

	<b>SD080201W60-D1</b>	DEVIL (HV 3800 ±200)	8,3	2,38	0,1	0,95	4 pz.
	<b>SD080201W60-ZRN</b>	ZRN (HV 2500 ±300)			0,1	0,95	4 pz.

SD080201W90... >> **IDEALE per:** Incidere e Scanalare a 90°

	<b>SD080201W90-D1</b>	DEVIL (HV 3800 ±200)	8,3	2,38	0,1	0,95	4 pz.
	<b>SD080201W90-ZRN</b>	ZRN (HV 2500 ±300)			0,1	0,95	4 pz.

## RIVESTIMENTO INSERTI: DEVIL

## KIT

## RIVESTIMENTO INSERTI: ZRN

COD.	COD.	COD.	COD.
KS01 S CT D1	KS01 S U1 D1	KS01 S CT ZRN	KS01 S U1 ZRN
<b>STELO</b> 1x SP1010-S	<b>STELO</b> 1x SP1010-S	<b>STELO</b> 1x SP1010-S	<b>STELO</b> 1x SP1010-S
<b>INSERTI</b>	<b>INSERTI</b>	<b>INSERTI</b>	<b>INSERTI</b>
6x SD080208CT-D1	2x SD080208CT-D1 2x SD080201W60-D1 2x SD080201W90-D1	6x SD080204CT-ZRN	2x SD080204CT-ZRN 2x SD080201W60-ZRN 2x SD080201W90-ZRN
<b>VITI e CHIAVE</b>	<b>VITI e CHIAVE</b>	<b>VITI e CHIAVE</b>	<b>VITI e CHIAVE</b>
2x SC30055 1x TORX-T8	2x SC30055 1x TORX-T8	2x SC30055 1x TORX-T8	2x SC30055 1x TORX-T8

I DATI INDICATI NON SONO IMPEGNATIVI E POSSONO ESSERE MODIFICATI ANCHE SENZA PREAVVISO.

# JOLLY B Ø16

MAX 16.000min<sup>-1</sup>

- SP1614-S
- SP1614-L

Utensili multifunzionali bilanciati a singolo tagliente per centrare, svasare, tornire, sfacciare, incidere, scanalare, smussare e raggiare.

Ogni stelo viene fornito di:  
1 Vite; 1 Chiave Torx.

In **Optional**:  
inserti per varie tipologie di lavorazioni e materiali.

**KIT Disponibili!** (Stelo + Inserti)

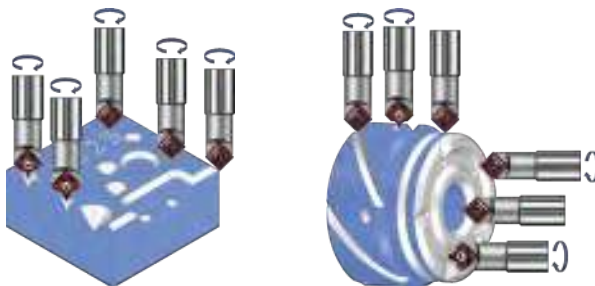

BILANCIATURA

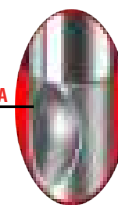

- SP1614-S
- SP1614-L

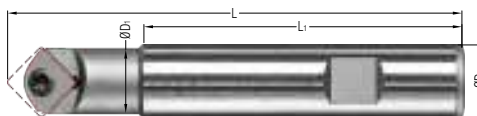

COD.	ØD [mm]	ØD1 [mm]	L [mm]	L1 [mm]	Vite (Inclusa)	Chiave (Inclusa)	Tipologia Inserti (Optional)
<b>JOLLY B</b>							
<b>STELI</b>							
SP1614-S	Ø16	Ø14	100	70	SC35087	TORX-T15	SD11T30.CT-...
SP1614-L			150	120			SD11T30.CTP60-...
<b>RICAMBI</b>							
SC35087					Vite Torx M3,5 H4x8,7 - 2,5Nm		
TORX-T15					Chiave Torx T15		

COD.	Rivestimento Inserto	Q [mm]	S [mm]	Re [mm]	ØD [mm]	R [mm]	H [mm]	X [mm]	Y [mm]	Minimo Ordine
<b>INSERTI</b>										
<b>SD11T30.CT-...</b>	>> <b>MULTIFUNZIONE per:</b> Centrare, Svasare, Tornire, Sfacciare, Incidere, Scanalare e Smussare									
SD11T304CT-D1	DEVIL (HV 3800 ±200)	11	3,97	0,4	-	-	7,2	-	-	10 pz.
SD11T308CT-D1				0,8	-	-	6,7	-	-	10 pz.
SD11T302CT-ZRN	ZRN (HV 2500 ±300)			0,2	-	-	7,4	-	-	10 pz.
SD11T304CT-ZRN				0,4	-	-	7,2	-	-	10 pz.
<b>SD11T30.CTP60-...</b>	>> <b>IDEALE per:</b> Centrare, Scanalare a 60° e Smussare a 30° • <b>Lavorazioni Secondarie:</b> Tornire, Incidere a 60° e Smussare a 45°									
SD11T308CTP60-D1	DEVIL (HV 3800 ±200)	11	3,97	0,8	-	-	4,4	-	-	4 pz.
SD11T304CTP60-ZRN	ZRN (HV 2500 ±300)			0,4	-	-	4,75	-	-	4 pz.
<b>SD11T30.CTD-...</b>	>> <b>IDEALE per:</b> Fori da Centro Raggiati a 60° (Simile DIN 332 Forma R) • <b>Lavorazioni Secondarie:</b> Centrare, Tornire, Incidere e Smussare									
SD11T308CTD20-D1	DEVIL (HV 3800 ±200)	11	3,97	0,8	2,0	-	3,9	-	-	4 pz.
SD11T308CTD25-D1					2,5	-	4,3	-	-	4 pz.
SD11T308CTD315-D1					3,15	-	4,8	-	-	4 pz.
SD11T304CTD20-ZRN	ZRN (HV 2500 ±300)	11	3,97	0,4	2,0	-	3,9	-	-	4 pz.
SD11T304CTD25-ZRN					2,5	-	4,3	-	-	4 pz.
SD11T304CTD315-ZRN					3,15	-	4,8	-	-	4 pz.
<b>SD11T308CTR-...</b>	>> <b>IDEALE per:</b> Raggiare • <b>Lavorazioni Secondarie:</b> Centrare, Tornire, Incidere e Smussare									
SD11T308CTR10-D1	DEVIL (HV 3800 ±200)	11	3,97	0,8	-	1,0	2,5	2,5	1,5	4 pz.
SD11T308CTR15-D1					-	1,5	3,0	3,0	1,5	4 pz.
SD11T308CTR20-D1					-	2,0	3,5	3,5	1,5	4 pz.
SD11T308CTR25-D1					-	2,5	4,0	4,0	1,5	4 pz.
SD11T308CTR30-D1					-	3,0	4,15	4,5	1,15	4 pz.
SD11T308CTR10-ZRN	ZRN (HV 2500 ±300)	11	3,97	0,8	-	1,0	2,5	2,5	1,5	4 pz.
SD11T308CTR15-ZRN					-	1,5	3,0	3,0	1,5	4 pz.
SD11T308CTR20-ZRN					-	2,0	3,5	3,5	1,5	4 pz.
SD11T308CTR25-ZRN					-	2,5	4,0	4,0	1,5	4 pz.
SD11T308CTR30-ZRN					-	3,0	4,15	4,5	1,15	4 pz.

# KIT JOLLY B Ø16

MAX 16.000min<sup>-1</sup>

• KS02 S... (Stelo SP1614-S)

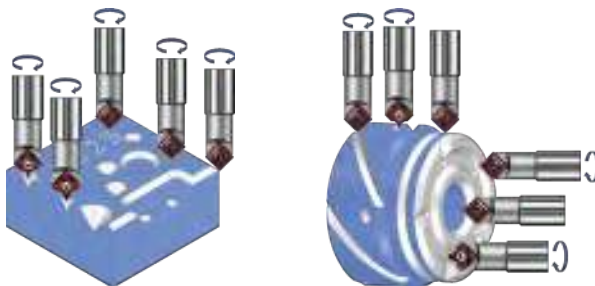

BILANCIATURA



KIT utensile multifunzionale bilanciato a singolo tagliente per centrare, svasare, tornire, sfacciare, incidere, scanalare e smussare.

Ogni KIT viene fornito di:

- 1 Stelo
- 6 Inserti
- 2 Viti
- 1 Chiave Torx
- 1 Confezione

• SP1614-S

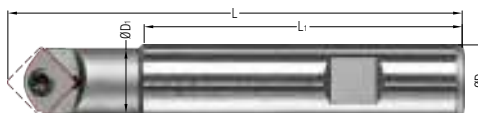

ØD [mm]	ØD1 [mm]	L [mm]	L1 [mm]
Ø16	Ø14	100	70

COD.	Rivestimento Inserto	Q [mm]	S [mm]	Re [mm]	ØD [mm]	H [mm]
------	----------------------	--------	--------	---------	---------	--------

## INSERTI per KIT

SD11T30.CT... >> **MULTIFUNZIONE per:** Centrare, Svasare, Tornire, Sfacciare, Incidere, Scanalare e Smussare

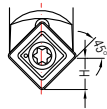
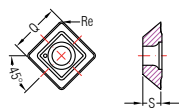

SD11T308CT-D1	DEVIL (HV 3800 ±200)	11	3,97	0,8	-	6,7
SD11T304CT-ZRN	ZRN (HV 2500 ±300)			0,4	-	7,2

SD11T30.CTP60... >> **IDEALE per:** Centrare, Scanalare a 60° e Smussare a 30° • **Lavorazioni Secondarie:** Tornire, Incidere a 60° e Smussare a 45°

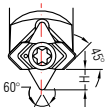
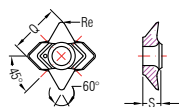

SD11T308CTP60-D1	DEVIL (HV 3800 ±200)	11	3,97	0,8	-	4,4
SD11T304CTP60-ZRN	ZRN (HV 2500 ±300)			0,4	-	4,75

SD11T30.CTD... >> **IDEALE per:** Fori da Centro Raggiati a 60° (Simile DIN 332 Forma R) • **Lavorazioni Secondarie:** Centrare, Tornire, Incidere e Smussare

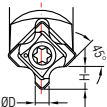
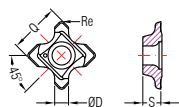

SD11T308CTD20-D1	DEVIL (HV 3800 ±200)	11	3,97	0,8	2,0	3,9
SD11T308CTD25-D1					2,5	4,3
SD11T308CTD315-D1					3,15	4,8
SD11T304CTD20-ZRN	ZRN (HV 2500 ±300)			0,4	2,0	3,9
SD11T304CTD25-ZRN					2,5	4,3
SD11T304CTD315-ZRN					3,15	4,8

## RIVESTIMENTO INSERTI: DEVIL

## KIT

## RIVESTIMENTO INSERTI: ZRN

COD.
KS02 S CT D1

COD.
KS02 S U1 D1

COD.	
KS02 S CT ZRN04	178,00

COD.
KS02 S U1 ZRN04



STELO	
1x SP1614-S	
INSERTI	VITI e CHIAVE
6x SD11T308CT-D1	2x SC35087 1x TORX-T15

STELO	
1x SP1614-S	
INSERTI	VITI e CHIAVE
2x SD11T308CT-D1 1x SD11T308CTP60-D1 1x SD11T308CTD20-D1 1x SD11T308CTD25-D1 1x SD11T308CTD315-D1	2x SC35087 1x TORX-T15

STELO	
1x SP1614-S	
INSERTI	VITI e CHIAVE
6x SD11T304CT-ZRN	2x SC35087 1x TORX-T15

STELO	
1x SP1614-S	
INSERTI	VITI e CHIAVE
2x SD11T304CT-ZRN 1x SD11T304CTP60-ZRN 1x SD11T304CTD20-ZRN 1x SD11T304CTD25-ZRN 1x SD11T304CTD315-ZRN	2x SC35087 1x TORX-T15

I DATI INDICATI NON SONO IMPEGNATIVI E POSSONO ESSERE MODIFICATI ANCHE SENZA PREAVVISO.

# JOLLY B Ø20

MAX 10.000min<sup>-1</sup>  
120°  
142°

- SP2017-120D-S (120°)
- SP2018-142D-S (142°)

Utensili multifunzionali bilanciati a singolo tagliente per centrare, svasare e smussare.

Ogni stelo viene fornito di:  
1 Vite; 1 Chiave Torx.

In Optional:  
inserti per varie tipologie di lavorazioni e materiali.

**KIT Disponibili!** (Stelo + Inserti)

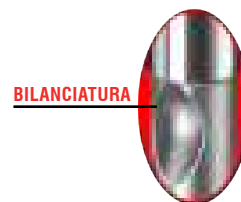
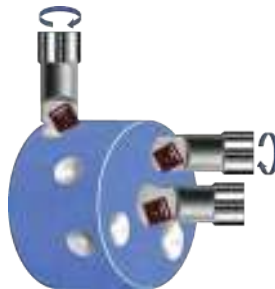
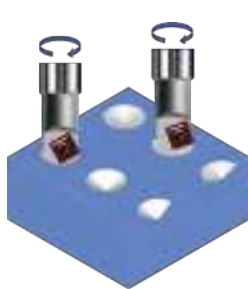

• SP2017-120D-S (120°)

• SP2018-142D-S (142°)

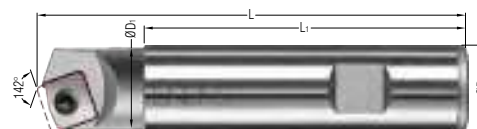
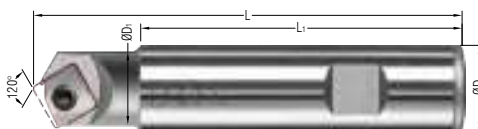

COD.	ØD [mm]	ØD1 [mm]	L [mm]	L1 [mm]	Vite (Inclusa)	Chiave (Inclusa)	Tipologia Inserti (Optional)
------	---------	----------	--------	---------	----------------	------------------	------------------------------

## JOLLY B



STELI		ØD	ØD1	L	L1	Vite (Inclusa)	Chiave (Inclusa)	Tipologia Inserti (Optional)
SP2017-120D-S	Ø20	Ø17	100	75	SC35087	TORX-T15	SD11T30.CT-...	
SP2018-142D-S	Ø20	Ø18,7						
RICAMBI								
SC35087	Vite Torx M3,5 H4x8,7 - 2,5Nm							
TORX-T15	Chiave Torx T15							

COD.	RIVESTIMENTO INSERTO	Q [mm]	S [mm]	Re [mm]	STELO	α [mm]	H [mm]	Minimo Ordine
------	----------------------	--------	--------	---------	-------	--------	--------	---------------

## INSERTI

SD11T30.CT-... >> **IDEALE per:** Centrare e Svasare a 120° o 142°, e Smussare a 60° o 71°

COD.	RIVESTIMENTO INSERTO	Q [mm]	S [mm]	Re [mm]	STELO	α [mm]	H [mm]	Minimo Ordine
SD11T304CT-D1	DEVIL (HV 3800 ±200)	11	3,97	0,4	SP2017-120D-S	120°	5,1	10 pz.
SD11T308CT-D1					SP2018-142D-S	142°	3,3	
SD11T302CT-ZRN	ZRN (HV 2500 ±300)	11	3,97	0,2	SP2017-120D-S	120°	5,3	10 pz.
SD11T304CT-ZRN					SP2018-142D-S	142°	3,4	
				0,4	SP2017-120D-S	120°	5,1	10 pz.
					SP2018-142D-S	142°	3,3	

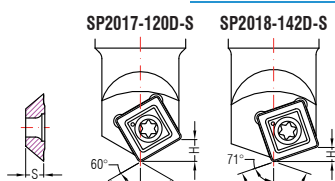
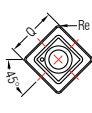

## RIVESTIMENTO INSERTI: DEVIL KIT RIVESTIMENTO INSERTI: ZRN

COD.	COD.	COD.	COD.
KS06 S CT D1	KS07 S CT D1	KS06 S CT ZRN04	KS07 S CT ZRN04
<b>STELO</b>	<b>STELO</b>	<b>STELO</b>	<b>STELO</b>
1x SP2017-120D-S	1x SP2018-142D-S	1x SP2017-120D-S	1x SP2018-142D-S
<b>INSERTI</b>	<b>INSERTI</b>	<b>INSERTI</b>	<b>INSERTI</b>
6x SD11T308CT-D1	6x SD11T308CT-D1	6x SD11T304CT-ZRN	6x SD11T304CT-ZRN
<b>VITI e CHIAVE</b>	<b>VITI e CHIAVE</b>	<b>VITI e CHIAVE</b>	<b>VITI e CHIAVE</b>
2x SC35087 1x TORX-T15	2x SC35087 1x TORX-T15	2x SC35087 1x TORX-T15	2x SC35087 1x TORX-T15



SP12-Z4-05-1219

SP1625R-S

SP16-Z1-11-1328

SP2017-18-S

SP20-Z4-11-2740

SP2020-28-S

SP20-Z4-11-2740-M12

Ra ≤

Ra ≤ 0,4 μm

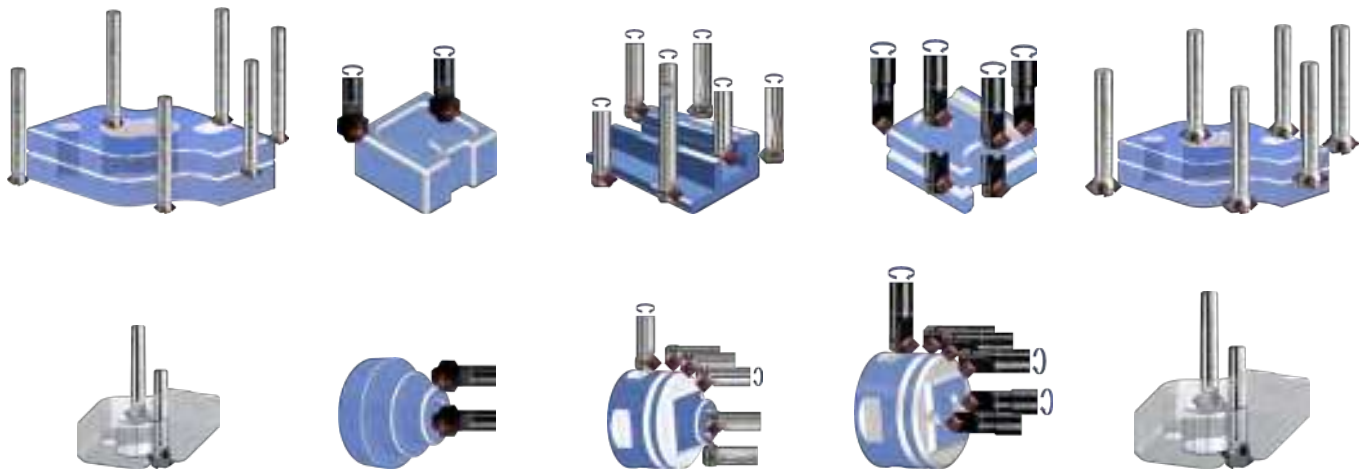

I DATI INDICATI NON SONO IMPEGNATIVI E POSSONO ESSERE MODIFICATI ANCHE SENZA PREAVVISO.

SCELTA DELL'INSERTO E SUE APPLICAZIONI

MODELLO STELO	TIPO DI LAVORAZIONE						ANGOLO	MATERIALE DA LAVORARE	RIVESTIMENTO
	FRESARE	SVASARE	TORNIRE	SFACCIARE	SMUSSARE	RAGGIARE			
							90°	ACCIAI LEGATI e INOX LEGATI ACCIAI AL CARBONIO GHISE MEEHANITE	DEVIL
								ACCIAIO INOX ALLUMINIO LEGHE NON FERROSE	ZRN
								MODELLO/TIPOLOGIA INSERTO	-D1 (DEVIL) -ZRN
SP12-Z4-05-1219	●	(2)			●	●		◆ SD050203-... ◆ SD050203R05-... ◆ SD050203R075-... ◆ SD050203R10-...	
SP1625R-S			(2)		●			◆ SD11T30-... ◆ SD11T308R10-... ◆ SD11T308R15-... ◆ SD11T308R20-... ◆ SD11T308R25-... ◆ SD11T308R30-...	
SP16-Z1-11-1328	●			●	●			◆ SD11T30-... ◆ SD11T308R10-... ◆ SD11T308R15-... ◆ SD11T308R20-... ◆ SD11T308R25-... ◆ SD11T308R30-...	
SP20-Z4-11-2740	●				●	●		◆ SD11T30-... ◆ SD11T308R10-... ◆ SD11T308R15-... ◆ SD11T308R20-... ◆ SD11T308R25-... ◆ SD11T308R30-...	
SP20-Z4-11-2740-M12	●	(2)			●	●		◆ SD11T30-... ◆ SD11T308R10-... ◆ SD11T308R15-... ◆ SD11T308R20-... ◆ SD11T308R25-... ◆ SD11T308R30-...	
SP2017-18-S		●	●	●	●			◆ SD11T30-...	
SP2020-28-S		●	●	●	●			◆ SD11T30-...	

(1) Lavorazioni ideali; (2)(3) Lavorazioni secondarie

I DATI INDICATI NON SONO IMPEGNATIVI E POSSONO ESSERE MODIFICATI ANCHE SENZA PREAVVISO.

# JOLLY Z4 Ø12

MAX 20.000min<sup>-1</sup>

• SP12-Z4-05-1219

Mini-Frese per lavorazioni di **finitura a quattro taglienti** per **fresare, smussare e raggiare** anche **sottosquadra**.

Ogni fresa viene fornita di:

4 Viti; 1 Chiave Torx.

In **Optional**:

inserti per varie tipologie di lavorazioni e materiali.

**KIT Disponibili!** (Stelo + Inserti)

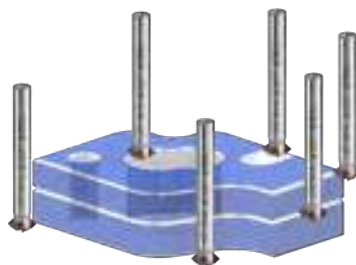

**Ra ≤ 0,4μm**

• SP12-Z4-05-1219

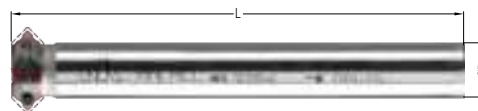

COD.	ØD [mm]	L [mm]	Vite (Inclusa)	Chiave (Inclusa)	Tipologia Inserti (Optional)
------	---------	--------	----------------	------------------	------------------------------

## JOLLY Z4



### STELI

SP12-Z4-05-1219	Ø12	100	SC20048	TORX-T6	SD050203-... SD050203R-...
-----------------	-----	-----	---------	---------	-------------------------------

### RICAMBI

SC20048	Vite Torx M2,0x4,8 - 0,8Nm
TORX-T6	Chiave Torx T6

COD.	Rivestimento Inserto	Q [mm]	S [mm]	Re [mm]	R [mm]	A [mm]	H [mm]	X [mm]	Y [mm]	Minimo Ordine
------	----------------------	--------	--------	---------	--------	--------	--------	--------	--------	---------------

## INSERTI

SD050202-... >> **IDEALE per:** Fresare e Smussare (anche Sottosquadra)

SD050203-D1	DEVIL (HV 3800 ±200)	5,3	2	0,3	-	5,8	3,3	-	-	10 pz.
SD050203-ZRN	ZRN (HV 2500 ±300)			0,3	-	5,8	3,3	-	-	10 pz.

SD050202R-... >> **IDEALE per:** Raggiare (anche Sottosquadra) • **Lavorazioni Secondarie:** Fresare e Smussare (anche Sottosquadra)

SD050203R05-D1	DEVIL (HV 3800 ±200)	5,3	2	0,3	-	5,8	-	7,95	1,4	4 pz.
SD050203R075-D1								8,05	1,27	4 pz.
SD050203R10-D1								8,2	1,15	4 pz.
SD050203R05-ZRN	ZRN (HV 2500 ±300)	5,3	2	0,3	-	5,8	-	7,95	1,4	4 pz.
SD050203R075-ZRN								8,05	1,27	4 pz.
SD050203R10-ZRN								8,2	1,15	4 pz.

## RIVESTIMENTO INSERTI: DEVIL **KIT** RIVESTIMENTO INSERTI: ZRN

COD.
KS12 Z4 03 D1

COD. (*RAGGIO A SCELTA)
KS12 Z4 R(*R) D1
(*R) 05 075 10
R 0,5 0,75 1,0

COD.
KS12 Z4 03 ZRN

COD. (*RAGGIO A SCELTA)
KS12 Z4 R(*R) ZRN
(*R) 05 075 10
R 0,5 0,75 1,0



STELO	
1x SP12-Z4-05-1219	
INSERTI	VITI e CHIAVE
4x SD050203-D1	5x SC20048 1x TORX-T6



STELO	
1x SP12-Z4-05-1219	
INSERTI	VITI e CHIAVE
4x SD050203R(*R)-D1	5x SC20048 1x TORX-T6



STELO	
1x SP12-Z4-05-1219	
INSERTI	VITI e CHIAVE
4x SD050203-ZRN	5x SC20048 1x TORX-T6



STELO	
1x SP12-Z4-05-1219	
INSERTI	VITI e CHIAVE
4x SD050203R(*R)-ZRN	5x SC20048 1x TORX-T6



# JOLLY Ø16

## • SP1625R-S

Utensili multifunzionali a singolo tagliente per tornire, smussare e raggiare.

Ogni stelo viene fornito di:  
1 Vite; 1 Chiave Torx.

In **Optional**:  
inserti per varie tipologie di lavorazioni e materiali.

**KIT Disponibili!** (Stelo + Inserti)

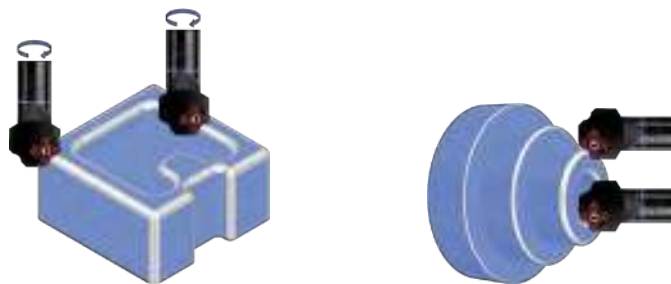

### SP1625R-S



I DATI INDICATI NON SONO IMPEGNATIVI E POSSONO ESSERE MODIFICATI ANCHE SENZA PREAVVISO.

COD.	ØD [mm]	ØD1 [mm]	L [mm]	L1 [mm]	Vite (Inclusa)	Chiave (Inclusa)	Tipologia Inserti (Optional)
------	---------	----------	--------	---------	----------------	------------------	------------------------------

### JOLLY



#### STELI

SP1625R-S	Ø16	Ø24	100	80	SC35087	TORX-T15	SD11T30... SD11T308R...-...
-----------	-----	-----	-----	----	---------	----------	--------------------------------

#### RICAMBI

SC35087	Vite Torx M3,5 H4x8,7 - 2,5Nm						
TORX-T15	Chiave Torx T15						

COD.	Rivestimento Inserto	Q [mm]	S [mm]	Re [mm]	R [mm]	A [mm]	H [mm]	X [mm]	Y [mm]	Minimo Ordine
------	----------------------	--------	--------	---------	--------	--------	--------	--------	--------	---------------

### INSERTI

#### SD11T30... >> IDEALE per: Smussare • Lavorazioni Secondarie: Tornire

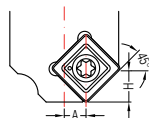
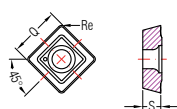

SD11T308-D1	DEVIL (HV 3800 ±200)	11	3,97	0,8	-	4,8	6,85	-	-	10 pz.
SD11T303-ZRN	ZRN (HV 2500 ±300)			0,3	-	4,8	7,4	-	-	10 pz.

#### SD11T308R...-... >> IDEALE per: Raggiare • Lavorazioni Secondarie: Tornire e Smussare

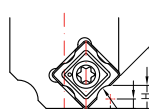
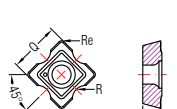

SD11T308R10-D1	DEVIL (HV 3800 ±200)	11	3,97	0,8	6,35	-	9,25	3,0	4 pz.
SD11T308R15-D1						-	9,5	2,83	4 pz.
SD11T308R20-D1						-	9,75	2,52	4 pz.
SD11T308R25-D1						-	10,0	2,27	4 pz.
SD11T308R30-D1				3,0		-	10,25	2,1	4 pz.
SD11T308R10-ZRN	ZRN (HV 2500 ±300)	11	3,97	0,8	6,35	-	9,25	3,0	4 pz.
SD11T308R15-ZRN						-	9,5	2,83	4 pz.
SD11T308R20-ZRN						-	9,75	2,52	4 pz.
SD11T308R25-ZRN						-	10,0	2,27	4 pz.
SD11T308R30-ZRN				3,0		-	10,25	2,1	4 pz.

### RIVESTIMENTO INSERTI: DEVIL

### KIT

### RIVESTIMENTO INSERTI: ZRN

COD.
KS08 S T3 D1

COD. (*RAGGIO A SCELTA)
KS08 S R(*R) D1
(*R) 10 15 20 25 30
R 1,0 1,5 2,0 2,5 3,0

COD.
KS08 S T3 ZRN

COD. (*RAGGIO A SCELTA)
KS08 S R(*R) ZRN
(*R) 10 15 20 25 30
R 1,0 1,5 2,0 2,5 3,0



STELO	
1x SP1625R-S	
INSERTI	VITI e CHIAVE
4x SD11T308-D1	2x SC35087 1x TORX-T15



STELO	
1x SP1625R-S	
INSERTI	VITI e CHIAVE
4x SD11T308R(*R)-D1	2x SC35087 1x TORX-T15



STELO	
1x SP1625R-S	
INSERTI	VITI e CHIAVE
4x SD11T303-ZRN	2x SC35087 1x TORX-T15



STELO	
1x SP1625R-S	
INSERTI	VITI e CHIAVE
4x SD11T308R(*R)-ZRN	2x SC35087 1x TORX-T15

I DATI INDICATI NON SONO IMPEGNATIVI E POSSONO ESSERE MODIFICATI ANCHE SENZA PREAVVISO.

# JOLLY Z1 Ø16

MAX 15.000min<sup>-1</sup>

• SP16-Z1-11-1328

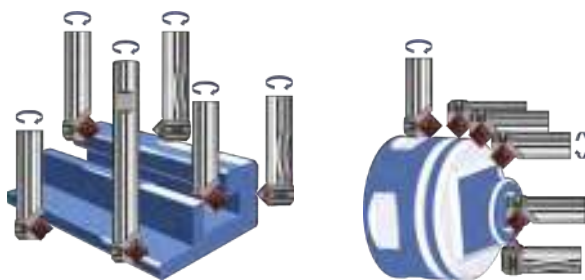

BILANCIATURA

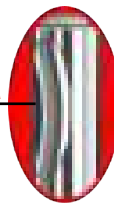

Mini-Frese per lavorazioni di finitura a singolo tagliente per fresare, svasare, tornire, smussare e raggiare anche sottosquadra.

Ogni fresa viene fornita di:

1 Vite; 1 Chiave Torx.

In **Optional**:

inserti per varie tipologie di lavorazioni e materiali.

**KIT Disponibili!** (Stelo + Inserti)

• SP16-Z1-11-1328

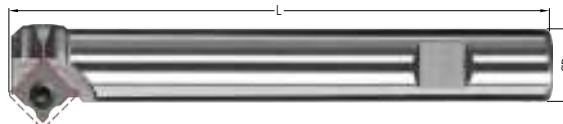

COD.	ØD [mm]	L [mm]	Vite (Inclusa)	Chiave (Inclusa)	Tipologia Inserti (Optional)
<b>JOLLY Z1</b>					
<b>STELI</b>					
SP16-Z1-11-1328	Ø16	120	SC35087	TORX-T15	SD11T30... SD11T308R...-...
<b>RICAMBI</b>					
SC35087	Vite Torx M3,5 H4x8,7 - 2,5Nm				
TORX-T15	Chiave Torx T15				

COD.	Rivestimento Inserto	Q [mm]	S [mm]	Re [mm]	R [mm]	A [mm]	H [mm]	X [mm]	Y [mm]	Minimo Ordine
<b>INSERTI</b>										
<b>SD11T30... &gt;&gt; IDEALE per:</b> Fresare, Svasare, Tornire e Smussare (anche Sottosquadra)										
SD11T308-D1	DEVIL (HV 3800 ±200)	11	3,97	0,8	-	6,35	6,85	-	-	10 pz.
SD11T303-ZRN	ZRN (HV 2500 ±300)			0,3	-	6,35	7,4	-	-	10 pz.
<b>SD11T308R... &gt;&gt; IDEALE per:</b> Raggiare (anche Sottosquadra) • <b>Lavorazioni Secondarie:</b> Fresare, Tornire e Smussare (anche Sottosquadra)										
SD11T308R10-D1	DEVIL (HV 3800 ±200)	11	3,97	0,8	6,35	1,0	-	10,75	3,0	4 pz.
SD11T308R15-D1						1,5	-	11,0	2,83	4 pz.
SD11T308R20-D1						2,0	-	11,25	2,52	4 pz.
SD11T308R25-D1						2,5	-	11,5	2,27	4 pz.
SD11T308R30-D1						3,0	-	11,75	2,1	4 pz.
SD11T308R10-ZRN	ZRN (HV 2500 ±300)	11	3,97	0,8	6,35	1,0	-	10,75	3,0	4 pz.
SD11T308R15-ZRN						1,5	-	11,0	2,83	4 pz.
SD11T308R20-ZRN						2,0	-	11,25	2,52	4 pz.
SD11T308R25-ZRN						2,5	-	11,5	2,27	4 pz.
SD11T308R30-ZRN						3,0	-	11,75	2,1	4 pz.

## RIVESTIMENTO INSERTI: DEVIL KIT RIVESTIMENTO INSERTI: ZRN

COD.	KS16 Z1 T3 D1
------	---------------

COD. (*RAGGIO A SCELTA)	KS16 Z1 R(*R) D1
(*R)	10 15 20 25 30
R	1,0 1,5 2,0 2,5 3,0

COD.	KS16 Z1 T3 ZRN
------	----------------

COD. (*RAGGIO A SCELTA)	KS16 Z1 R(*R) ZRN
(*R)	10 15 20 25 30
R	1,0 1,5 2,0 2,5 3,0



STELO	1x SP16-Z1-11-1328
INSERTI	4x SD11T308-D1
VITI e CHIAVE	2x SC35087 1x TORX-T15



STELO	1x SP16-Z1-11-1328
INSERTI	4x SD11T308R(*R)-D1
VITI e CHIAVE	2x SC35087 1x TORX-T15



STELO	1x SP16-Z1-11-1328
INSERTI	4x SD11T303-ZRN
VITI e CHIAVE	2x SC35087 1x TORX-T15

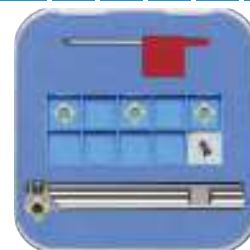

STELO	1x SP16-Z1-11-1328
INSERTI	4x SD11T308R(*R)-ZRN
VITI e CHIAVE	2x SC35087 1x TORX-T15



# JOLLY Z4 Ø20

MAX 15.000min<sup>-1</sup>

- SP20-Z4-11-2740
- SP20-Z4-11-2740-M12

Mini-Frese per lavorazioni di finitura a quattro taglienti per fresare, smussare e raggiare anche sottosquadra.

Ogni fresa viene fornita di: 4 Viti; 1 Chiave Torx.

In Optional: inserti per varie tipologie di lavorazioni e materiali.

KIT Disponibili! (Stelo + Inserti)

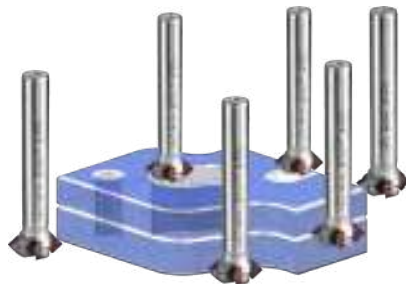

Ra ≤ 0,4μm

• SP20-Z4-11-2740



• SP20-Z4-11-2740-M12

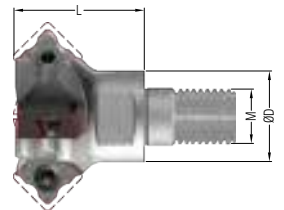

COD.	ØD [mm]	M	L [mm]	Vite (Inclusa)	Chiave (Inclusa)	Tipologia Inserti (Optional)
------	---------	---	--------	----------------	------------------	------------------------------

## JOLLY Z4



### STELI

SP20-Z4-11-2740	Ø20	-	140	SC35087	TORX-T15	SD11T30-... SD11T308R-...
SP20-Z4-11-2740-M12		M12	28			

### RICAMBI

SC35087	Vite Torx M3,5 H4x8,7 - 2,5Nm
TORX-T15	Chiave Torx T15

COD.	Rivestimento Inserto	Q [mm]	S [mm]	Re [mm]	R [mm]	A [mm]	H [mm]	X [mm]	Y [mm]	Minimo Ordine
------	----------------------	--------	--------	---------	--------	--------	--------	--------	--------	---------------

## INSERTI

### SD11T30-...

>> IDEALE per: Fresare e Smussare (anche Sottosquadra)

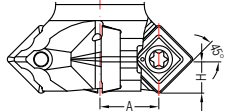
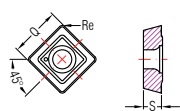

SD11T308-D1	DEVIL (HV 3800 ±200)	11	3,97	0,8	-	12,95	6,85	-	-	10 pz.
SD11T303-ZRN	ZRN (HV 2500 ±300)			0,3	-	12,95	7,4	-	-	10 pz.

### SD11T308R-...

>> IDEALE per: Raggiare (anche Sottosquadra) • Lavorazioni Secondarie: Fresare e Smussare (anche Sottosquadra)

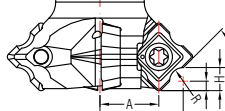
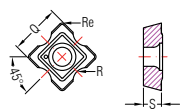

SD11T308R10-D1	DEVIL (HV 3800 ±200)	11	3,97	0,8	1,0	-	12,95	17,3	3,0	4 pz.
SD11T308R15-D1					1,5	-	12,95	17,55	2,83	4 pz.
SD11T308R20-D1					2,0	-	12,95	17,8	2,52	4 pz.
SD11T308R25-D1					2,5	-	12,95	18,05	2,27	4 pz.
SD11T308R30-D1					3,0	-	12,95	18,3	2,1	4 pz.
SD11T308R10-ZRN	ZRN (HV 2500 ±300)	11	3,97	0,8	1,0	-	12,95	17,3	3,0	4 pz.
SD11T308R15-ZRN					1,5	-	12,95	17,55	2,83	4 pz.
SD11T308R20-ZRN					2,0	-	12,95	17,8	2,52	4 pz.
SD11T308R25-ZRN					2,5	-	12,95	18,05	2,27	4 pz.
SD11T308R30-ZRN					3,0	-	12,95	18,3	2,1	4 pz.

## RIVESTIMENTO INSERTI: DEVIL

## KIT

## RIVESTIMENTO INSERTI: ZRN

COD.
KS20 Z4 T3 D1

COD. (*RAGGIO A SCELTA)
KS20 Z4 R(*R) D1
(*R) 10 15 20 25 30
R 1,0 1,5 2,0 2,5 3,0

COD.
KS20 Z4 T3 ZRN

COD. (*RAGGIO A SCELTA)
KS20 Z4 R(*R) ZRN
(*R) 10 15 20 25 30
R 1,0 1,5 2,0 2,5 3,0



STELO	
1x SP20-Z4-11-2740	
INSERTI	VITI e CHIAVE
4x SD11T308-D1	5x SC35087 1x TORX-T15



STELO	
1x SP20-Z4-11-2740	
INSERTI	VITI e CHIAVE
4x SD11T308R(*R)-D1	5x SC35087 1x TORX-T15



STELO	
1x SP20-Z4-11-2740	
INSERTI	VITI e CHIAVE
4x SD11T303-ZRN	5x SC35087 1x TORX-T15



STELO	
1x SP20-Z4-11-2740	
INSERTI	VITI e CHIAVE
4x SD11T308R(*R)-ZRN	5x SC35087 1x TORX-T15

I DATI INDICATI NON SONO IMPEGNATIVI E POSSONO ESSERE MODIFICATI ANCHE SENZA PREAVVISO.

# JOLLY Ø20

- SP2017-18-S
- SP2020-28-S

Utensili multifunzionali a singolo tagliente per svasare, tornire, sfacciare e smussare anche sottosquadra (solo SP2020-28-S).

Ogni stelo viene fornito di:

1 Vite; 1 Chiave Torx.

In **Optional**:

inserti per varie tipologie di lavorazioni e materiali.

**KIT Disponibili!** (Stelo + Inserti)

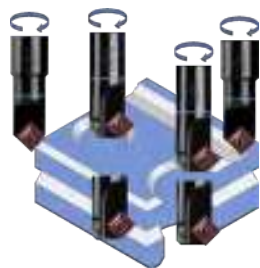

• SP2017-18-S

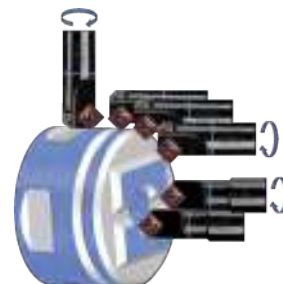

• SP2020-28-S

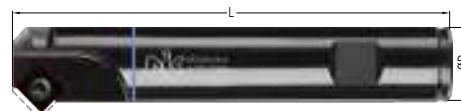

COD.	ØD [mm]	ØD1 [mm]	L [mm]	L1 [mm]	Vite (Inclusa)	Chiave (Inclusa)	Tipologia Inserti (Optional)
------	---------	----------	--------	---------	----------------	------------------	------------------------------

## JOLLY



STELI		RICAMBI	
SP2017-18-S	Ø20	Ø17	80
SP2020-28-S	Ø20	-	-
SC35087	Vite Torx M3,5 H4x8,7 - 2,5Nm		
TORX-T15	Chiave Torx T15		

COD.	RIVESTIMENTO INSERTO	Q	S	Re	STELO	A	H	Minimo Ordine
		[mm]	[mm]	[mm]		[mm]	[mm]	

## INSERTI

SD11T30-...		>> IDEALE per: Smussare (anche Sottosquadra con SP2020-28-S) • Lavorazioni Secondarie: Svasare, Tornire e Sfacciare						
SD11T308-D1	DEVIL (HV 3800 ±200)	11	3,97	0,8	SP2017-18-S	1,3	6,7	10 pz.
SD11T303-ZRN	ZRN (HV 2500 ±300)			0,3	SP2017-18-S	1,3	7,3	10 pz.
					SP2020-28-S	6,5	6,85	
					SP2020-28-S	6,5	7,4	

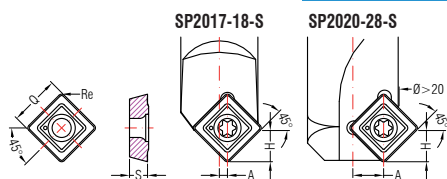

## RIVESTIMENTO INSERTI: DEVIL KIT RIVESTIMENTO INSERTI: ZRN

COD.	COD.	COD.	COD.
KS04 S T3 D1	KS05 S T3 D1	KS04 S T3 ZRN	KS05 S T3 ZRN
<b>STELO</b> 1x SP2017-18-S	<b>STELO</b> 1x SP2020-28-S	<b>STELO</b> 1x SP2017-18-S	<b>STELO</b> 1x SP2020-28-S
<b>INSERTI</b> 4x SD11T308-D1	<b>INSERTI</b> 4x SD11T308-D1	<b>INSERTI</b> 4x SD11T303-ZRN	<b>INSERTI</b> 4x SD11T303-ZRN
<b>VITI e CHIAVE</b> 2x SC35087 1x TORX-T15	<b>VITI e CHIAVE</b> 2x SC35087 1x TORX-T15	<b>VITI e CHIAVE</b> 2x SC35087 1x TORX-T15	<b>VITI e CHIAVE</b> 2x SC35087 1x TORX-T15





**SINERGYA È ORA PARTE DI EMMEPI UTENSILERIA.**



**SCOPRI LA GAMMA  
COMPLETA  
E AGGIORNATA**

[utensileria.it/sinergya/](https://utensileria.it/sinergya/)



**Emmepi Utensileria s.r.l.**  
SEDE LEGALE  
+39 0445 576210  
Via Lago di Albano, 5 - 36015 Schio (VI)



**Cuma**  
DIVISIONE PRODUZIONE  
+39 049 870 0810  
Viale della Regione Veneto, 22, 35127 Padova (PD)

[utensileria.it](https://utensileria.it)  
[ordini@utensileria.it](mailto:ordini@utensileria.it)