



DO-GRIP • **JETCUT**

JET HP LINE

**Nuove Lame per Troncatura con
Condotti per la Refrigerazione ad Elevata
Pressione ed Inserti DO-GRIP**





Caratteristiche

ISCAR ha ampliato la linea di utensili e lame per troncatura con refrigerazione ad elevata pressione introducendo le lame per inserti DO-GRIP

Le nuove lame **DGFH 32-#-JHP** sono disponibili per inserti con larghezza da 2 a 6 mm.

Tutte le informazioni tecniche sono riportate nella ANP B-16-001, e possono essere consultate anche sul catalogo JETHPLINE insieme alla linea completa di blocchi, lame ed utensili JHP.

Vantaggi delle lame DGFH-JHP

- Riducono la temperatura nella zona di taglio
- Migliorano la finitura e la durata inserto
- La refrigerazione ad elevata pressione previene o elimina la formazione del tagliente di riporto, specialmente nella lavorazione di acciai inox e superleghe
- Eccellente rottura del truciolo su tutti i materiali

Nota

Le lame possono essere utilizzate con gli inserti standad DGN, mentre non possono montare gli inserti DGNC.

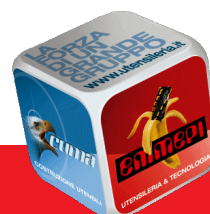



DGFH-JHP

Lame per troncatura e scanalatura con condotti per la refrigerazione ad elevata pressione - Per inserti DO-GRIP

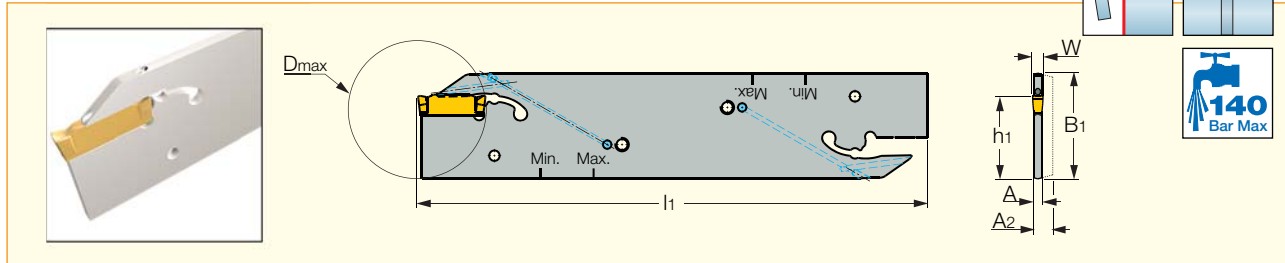

Descrizione	W _{min}	W _{max}	A	A ₂	I ₁	B ₁	h ₁	D _{max}	Inserti
DGFH 32-2-JHP	1.90 ⁽¹⁾	2.50	1.80	2.4	150.00	32.0	24.8	39.0	DG. 1.../DG. 2...
DGFH 32-3-JHP	3.00 ⁽¹⁾	3.18	2.50	-	150.00	32.0	24.8	90.0	DG. 1.../DG. 3...
DGFH 32-4-JHP	4.00	4.00	3.20	-	150.00	32.0	24.9	90.0	DG. 4.../GRIP 4...
DGFH 32-5-JHP	5.00	5.00	4.00	-	150.00	32.0	24.9	90.0	DG. 5.../GRIP 5...
DGFH 32-6-JHP	6.00	6.35	5.20	-	160.00	32.0	24.9	90.0	DG. 6.../GRIP 6...

⁽¹⁾ Per inserti DG. 1... è necessario modificare la sede

Ricambi

Descrizione	Estrattore	Vite a tenuta
DGFH-JHP	EDG 33A-JHP*	SGC 340

* (Opzionale, ordinare separatamente)

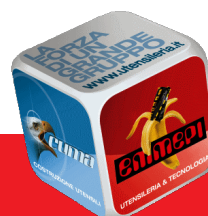
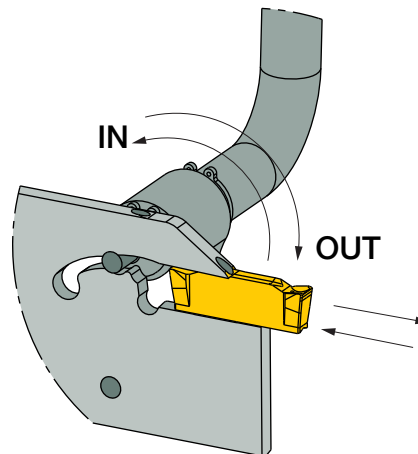

DO-GRIP • JETCUT
JET HP LINE

TGTBU-JHP

Blocchi per lame di troncatura e scanalatura
Per refrigerazione ad elevata pressione

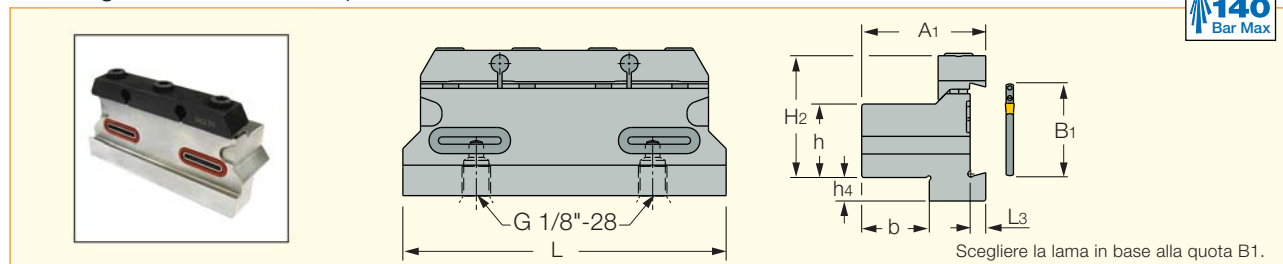

Descrizione	h	b	B ₁	A ₁	H ₂	h ₄	L ₃	L
TGTBU 16-5G-JHP	16.0	16.9	26.0	35.60	29.9	13.1	4.10	86.00
TGTBU 20-5G-JHP	20.0	20.9	26.0	39.60	33.9	9.1	4.10	86.00
TGTBU 20-6G-JHP	20.0	19.0	32.0	39.20	36.4	15.0	5.30	100.00
TGTBU 25-5G-JHP	25.0	26.1	26.0	44.10	39.0	5.5	4.10	110.00
TGTBU 25-6G-JHP	25.0	23.0	32.0	43.20	41.4	8.0	5.30	110.00
TGTBU 32-6G-JHP	32.0	29.0	32.0	49.20	48.4	5.0	5.30	110.00

Ricambi

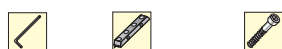

Descrizione	Chiave	Staffa	Vite
TGTBU 16-5G-JHP	HW 5.0	BKU 86	SR M6X16DIN912 12.9
TGTBU 20-5G-JHP	HW 5.0	BKU 86	SR M6X16DIN912 12.9
TGTBU 20-6G-JHP	HW 5.0	BKU 100	SR M6X16DIN912 12.9
TGTBU 25-5G-JHP	HW 5.0	BKU 105	SR M6X16DIN912 12.9
TGTBU 25-6G-JHP	HW 5.0	BKU 110	SR M6X16DIN912 12.9
TGTBU 32-6G-JHP	HW 5.0	BKU 110	SR M6X16DIN912 12.9

